

ATARI

600 XL™ COMPUTER FIELD SERVICE MANUAL



 A Warner Communications Company

FD100610
REV. 1
OCTOBER 1983

COPYRIGHT © 1983 BY ATARI, INC. ALL RIGHTS RESERVED.

No part of this publication may be reproduced by any mechanical, photographic, or electronic process, or in the form of a phonographic recording, nor may it be stored in a retrieval system, transmitted, or otherwise copied for public or private use, without permission from ATARI, Inc.

Published By:
ATARI, INC.
1265 Borregas Avenue
P.O. Box 427
Sunnyvale, California 94086

ATARI
600XL™ COMPUTER
FIELD SERVICE MANUAL

Atari believes that the information described in this manual is accurate and reliable, and much care has been taken in its preparation. However, no responsibility, financial or otherwise, shall be accepted for any consequences arising out of the use of this material. Information contained herein is subject to change. Revisions may be issued to advise of such changes and/or additions.

Correspondence regarding this document should be forwarded to Director of Technical Support, Consumer Product Service, Atari, Incorporated, 1272 Borregas Avenue, Sunnyvale, California 94086.

TABLE OF CONTENTS

<u>Section</u>	<u>Title</u>	<u>Page</u>
	INTRODUCTION	vii
1	THEORY OF OPERATION	1-1
	User Interface	1-1
	Mechanical Theory	1-1
	Electrical Theory	1-4
	6502C CPU Microprocessor	1-4
	Alphanumeric Television	
	Interface Controller (ANTIC)	1-5
	Graphic Television	1-6
	Interface Adaptor (GTIA)	
	Pot Keyboard Integrated Circuit (POKEY)	1-7
	Peripheral Interface Adaptor (PIA)	1-8
	Memory (ROMs and DRAMs)	1-9
	OS ROM	1-9
	BASIC ROM	1-9
	DRAMs	1-9
	Memory Management Unit (MMU)	1-9
	RF Modulator	1-10
	Power Supply	1-10
	System Interface	1-11
	Serial Input/Output (SIO) Interface	1-11
	Keyboard Interface	1-12
	Controller Jack Interfaces	1-13
	Cartridge Interface	1-13
	Parallel Bus Interface	1-15
2	TESTING AND TROUBLESHOOTING	2-1
	Overview	2-1
	Equipment Needed	2-1
	Self Test Features	2-1
	Description of Self Tests	2-2
	Memory Test	2-2
	Audio Visual Test	2-2
	Keyboard Test	2-2
	All Tests	2-3
	Super SALT Features	2-3
	Overview	2-3
	Performance Test	2-3
	Extended Unit Test	2-4
	Individual Tests	2-4
	Change Test Opts	2-4
	Show Err Summary	2-4
	Super SALT Testing Procedures	2-4

TABLE OF CONTENTS

<u>Section</u>	<u>Title</u>	<u>Page</u>
	Performance Test	2-7
	2-Way Clock Test	2-7
	6502 Test	2-9
	ANTIC Stress Test	2-9
	Bar Test	2-10
	Color Bars	2-11
	GTIA Diagnostic	2-12
	I/O Port Test	2-14
	OS ROM Checksum	2-16
	RAM Test	2-17
	Tone Test	2-18
	Video Test	2-18
	Xternal Audio	2-19
	Individual Tests	2-20
	Joystick Test	2-21
	Keyboard Test	2-21
	Maintenance Mode	2-22
	Paddle Test	2-23
	Change Test Opts and Extend Unit Test	2-24
	Show Err Summary	2-26
3	SYMPTOM CHECKLIST	3-1
4	DISASSEMBLY/ASSEMBLY INSTRUCTIONS	4-1
5	SCHEMATICS AND SILKSCREENS, AND PARTS LIST	5-1
6	SERVICE BULLETINS	6-1

LIST OF ILLUSTRATIONS

<u>Figure</u>	<u>Title</u>	<u>Page</u>
1-1	Functional Block Diagram	1-2
1-2	Functional Block Diagram	1-3
1-3	6502C CPU Pin Assignments	1-5
1-4	ANTIC Display Processor Pin Assignments	1-6
1-5	GTIA Pin Assignments	1-7
1-6	POKEY Pin Assignments	1-8
1-7	PIA Pin Assignments	1-9
1-8	Power Supply Pin Assignments	1-10
1-9	SIO Connector Pin Assignments	1-12
1-10	Controller Jack Pin Assignments	1-13

LIST OF ILLUSTRATIONS

<u>Figure</u>	<u>Title</u>	<u>Page</u>
1-11	Cartridge Connector Pin Assignments	1-14
1-12	PBI Connector Pin Assignments	1-16
2-1	Super SALT Extended Hardware	2-5
2-2	Title Screen	2-6
2-3	Executive Menu Screen	2-7
2-4	Performance Test Screen	2-8
2-5	2-Way Clock Screen	2-8
2-6	6502 Test Screen	2-9
2-7	ANTIC Stress Screen	2-10
2-8	Bar Test Screen	2-11
2-9	Color Bar Screen	2-12
2-10	GTIA Diagnostic Screen (Part 1)	2-12
2-11	GTIA Diagnostic Screen (Part 2)	2-13
2-12	GTIA Diagnostic Screen (Part 3)	2-13
2-13	I/O Port Test Screen (Voltage Test)	2-15
2-14	I/O Port Test Screen (I/O Tests Done)	2-15
2-15	OS ROM Checksum Screen	2-16
2-16	RAM Test Screen (Screen 1)	2-17
2-17	RAM Test Screen (Screen 2)	2-17
2-18	Tone Test Screen	2-18
2-19	Video Test Screen	2-19
2-20	Xternal Audio Screen	2-19
2-21	Individual Tests Menu Screen	2-20
2-22	Joystick Test Screen	2-21
2-23	Keyboard Test Screen	2-22
2-24	Paddle Test Screen	2-23
2-25	Change Test Opts Screen	2-24
2-26	Extend Unit Test Screen (Selection)	2-25
2-27	Extend Unit Test Screen	2-25
2-28	System Error Summary Screen	2-26
2-29	6502 Error Summary Screen	2-27
2-30	OS ROM Checksum Error Summary Screen	2-27
2-31	RAM Error Summary Screen	2-28
2-32	GTIA Error Summary Screen	2-28
2-33	PIA Error Summary Screen	2-29
2-34	POKEY Error Summary Screen	2-29
2-35	Timers/RAN # Gen Error Summary Screen	2-30
2-36	Baud Rate Error Summary Screen	2-30
5-1	600XL Silkscreen	5-3

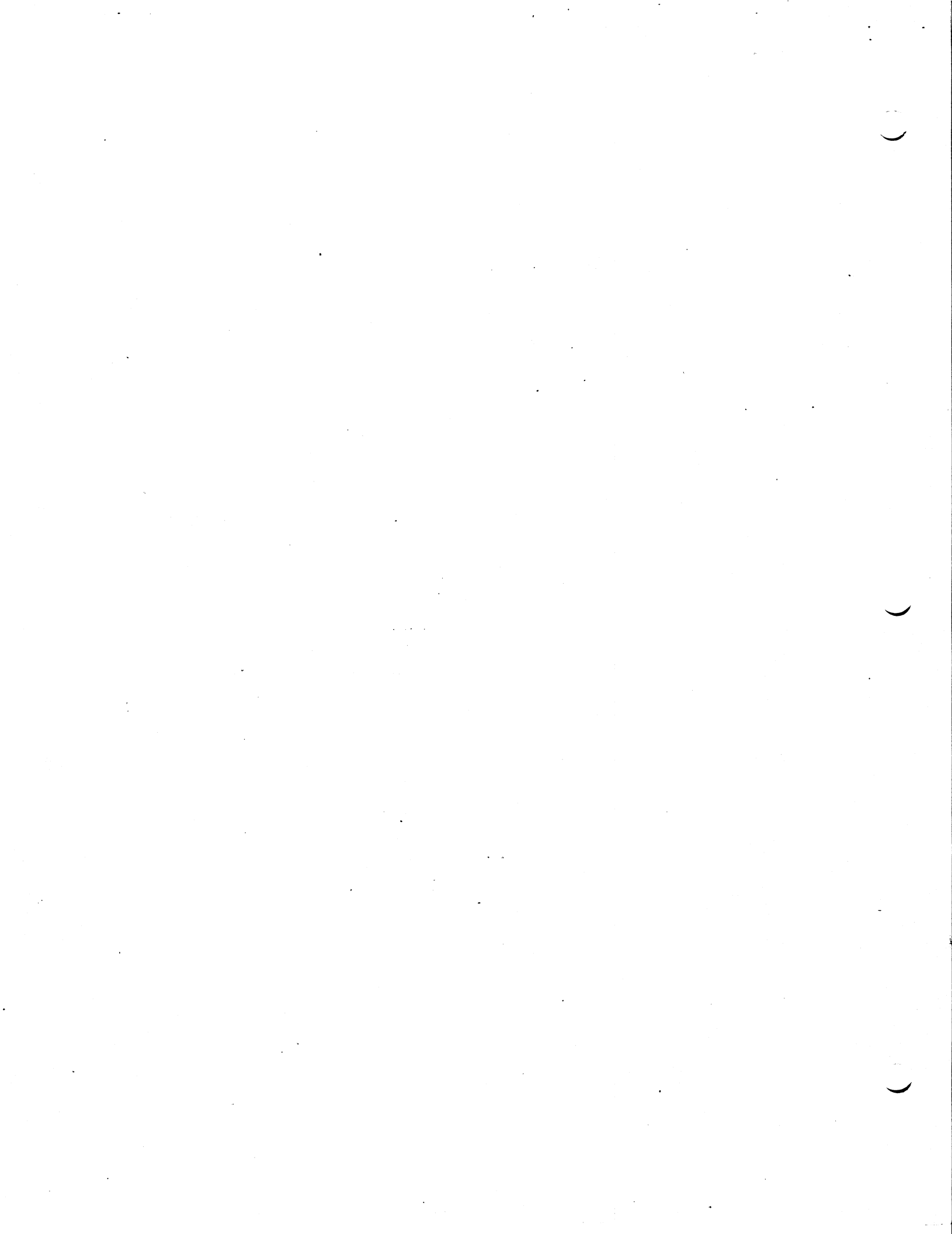

INTRODUCTION

The Atari 600XL™ Computer Field Service Manual is a reference guide for the service technician.

The Field Service Manual is organized into six sections:

- o **THEORY OF OPERATION** - Overview of how the 600XL works and what its basic assemblies look like.
- o **TESTING** - Review of Diagnostic tests available for diagnosing 600XL problems.
- o **SYMPTOM CHECKLIST** - Failure information to aid the technician for a rapid diagnosis of 600XL problems.
- o **ASSEMBLY/DISASSEMBLY** - Assembly/Disassembly instructions.
- o **SCHEMATICS AND SILKSCREENS, AND PARTS LIST** - Electrical drawings and layouts of the 600XL Printer Circuit Board and a list of the parts used.
- o **SERVICE BULLETINS** - Section to be used for Field Change Orders, Upgrade Bulletins and Tech Tips.

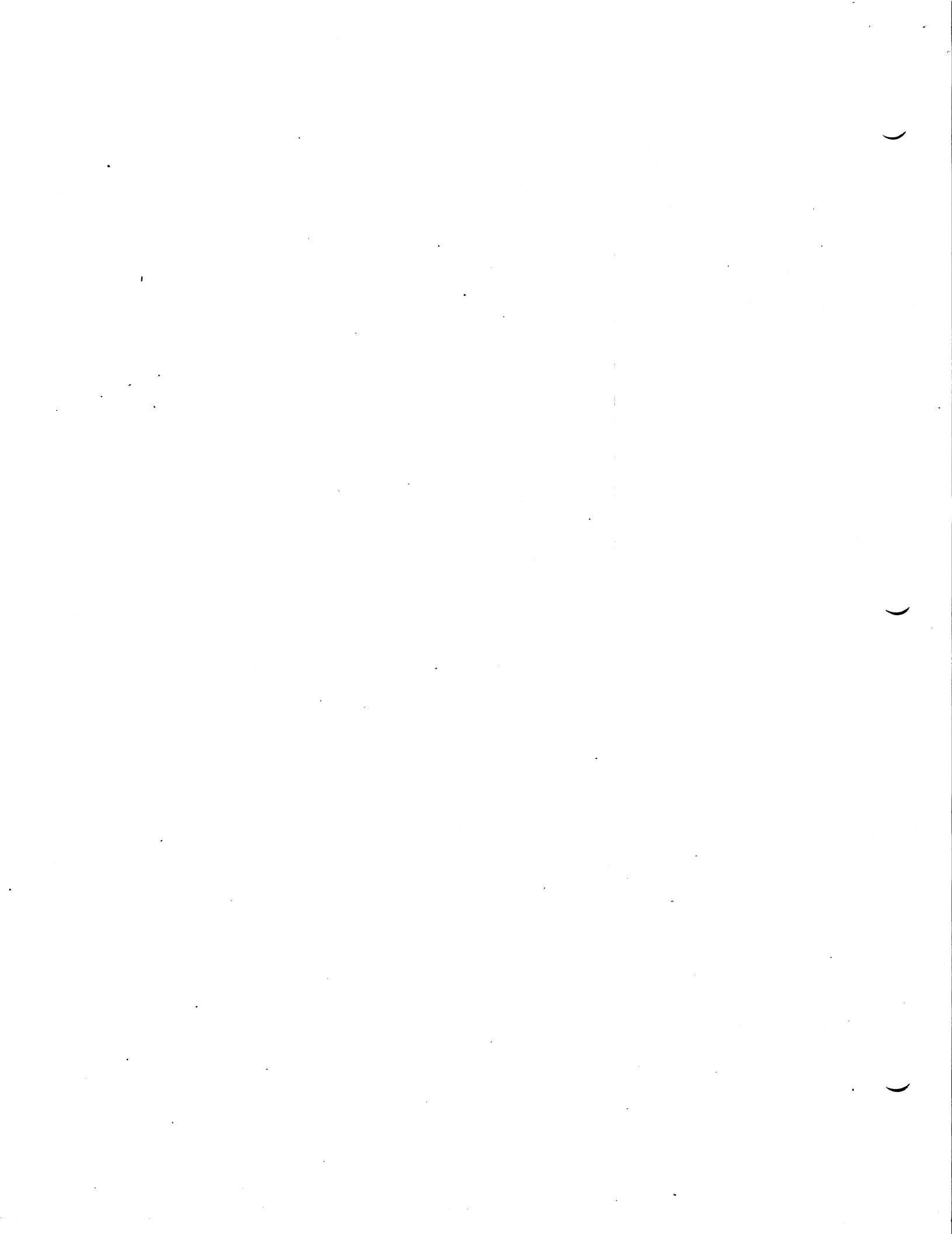

SECTION 1

THEORY OF OPERATION

The Atari 600XL™ is an enhanced version of the existing ATARI Computer Systems. It can be used with any of the existing Atari peripheral devices used with the 400/800/1200XL Computers.

The PCB contains 16K of RAM (expandable to 64K through the parallel interface), an operating system that contains one 16K X 8 ROM and an on-board Atari BASIC programming language I.C. The console contains the keyboard and four function keys (including a HELP key), plus a RESET key, a single cartridge slot, connector jack for daisy-chaining peripherals and connecting hand controllers, a detachable (RF) TV interface cable, one status LED (POWER), and a parallel bus interface (PBI).

USER INTERFACE

The Atari 600XL is a general purpose microcomputer that uses a 6502C microprocessor. The 600XL console is the central processing unit for its respective system.

The right side panel contains the controller jacks that accept the Atari X-Y joysticks and paddle controllers.

The rear panel contains the serial input/output (SIO) jack, the PBI, the RF jack, the channel 2-3 switch, the power in jack, and the power switch (On/Off).

The console has a 3/4 stroke, 56 key, alphanumeric keyboard, that includes special characters and controls, space bar, four function keys, HELP key, and power indicator. The function and HELP keys are discussed below.

FUNCTION KEYS

RESET - Interrupts and restarts the operating system (OS) or cartridge. When pressed while the computer is ON, this key enables the BASIC.

START - Starts the game or program.

SELECT - Selects different program or game variations.

OPTION - Allows the player to choose variations of a program. If the OPTION Key is not depressed and held at the time the computer is turned ON, the built-in BASIC is automatically enabled. If the OPTION key is depressed and held at the same time the computer is turned ON, the on board BASIC is disabled and, when there is no cartridge or diskette in the system, the Self-Test menu appears.

HELP - Returns to main self-test menu from individual test and for future software development for user "help" functions. If you are familiar with 1200XL operation, this key does not function the same.

MECHANICAL THEORY

The 600XL computer console contains a single motherboard which houses all the chips of the system and provides connectors for interfacing external modules to the console. It includes the CPU, RAM, OS and BASIC ROM's. The motherboard uses a common address bus, data bus and clock lines. The sixteen-line address bus allows the microprocessor to directly address 16K (expandable thru PBI) memory locations. The eight-line data bus provides the communication and data path between the functional modules. The power is provided by an external power supply and routed throughout the console.

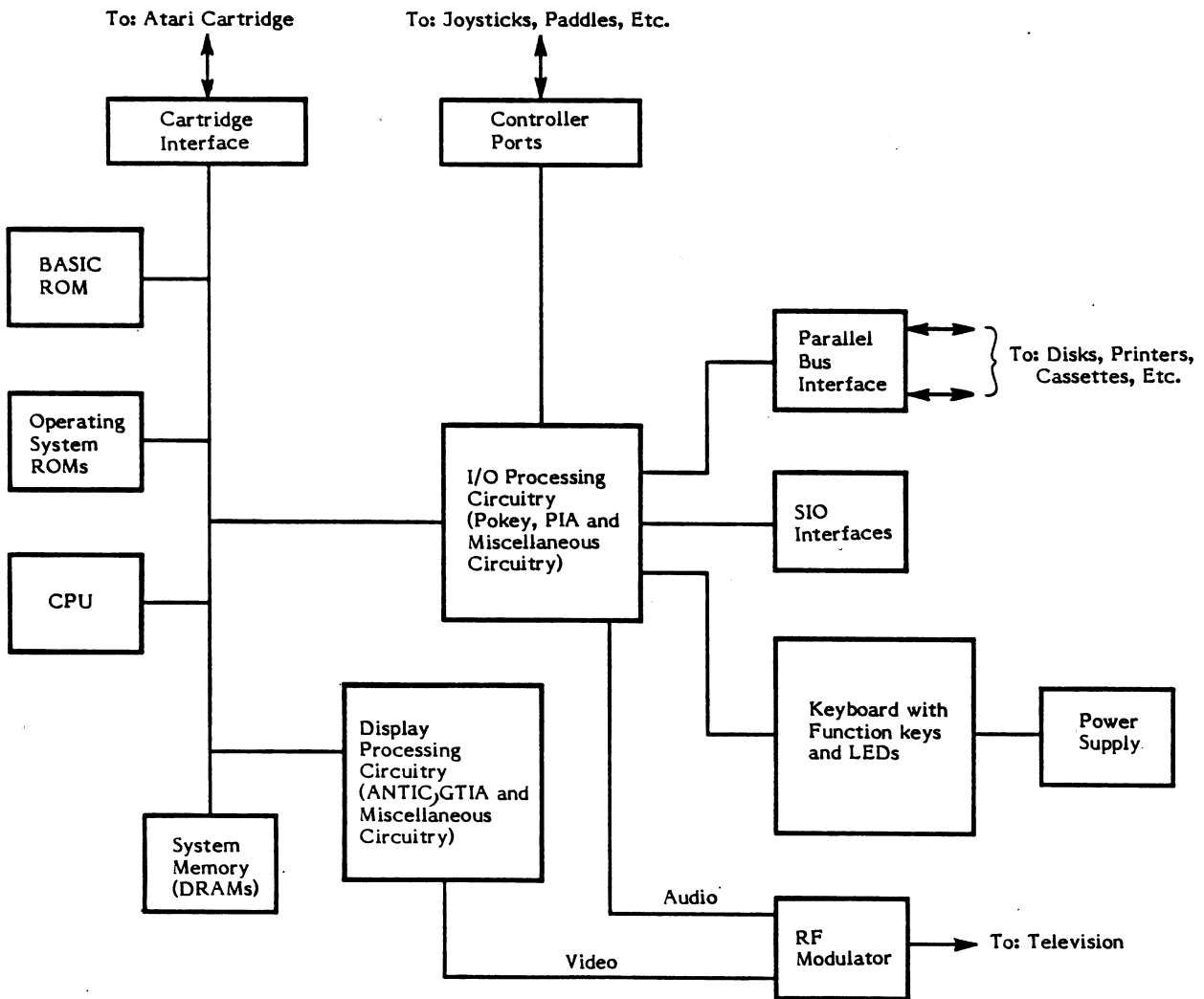

Figure 1-1. Functional Block Diagram

The keyboard connects to the PC Board by a 24-conductor ribbon cable.

The keyboard is the user interface with the computer.

All peripherals connect to the 600XL either through the SIO connector or the PBI. Power enters through the 7-Pin DIN connector on the rear panel. RF to the TV switchbox arrives from an RCA phono connector and RF cable. Power On/Off is controlled by the ON/OFF switch on the rear panel.

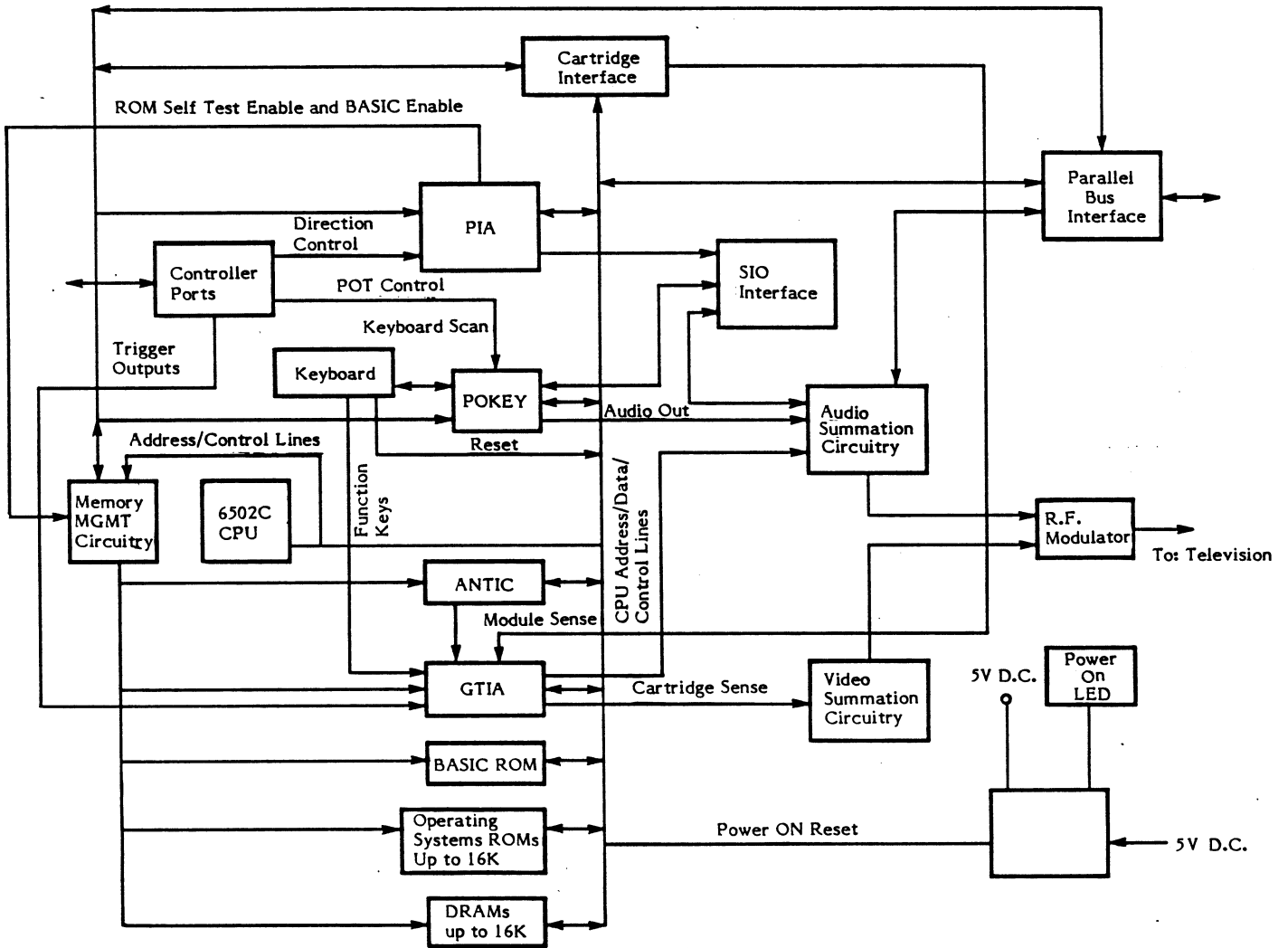

Figure 1-2. Functional Block Diagram

ELECTRICAL THEORY

DIGITAL HARDWARE

The digital hardware consists of:

- o The 6502C CPU microprocessor
- o The Alphanumeric Television Interface Controller (ANTIC)
- o The Graphics Television Interface Adaptor (GTIA)
- o The POT KEYboard Integrated Circuit (POKEY)
- o The Peripheral Interface Adaptor (PIA)
- o The Memory (O.S. ROM, 16K RAM, Atari BASIC ROM, Rev. B)
- o Miscellaneous Logic
 - Memory Management Unit (MMU)
 - Delay Line
- o Parallel Bus Interface (PBI)

6502C CPU Microprocessor

The 6502C CPU microprocessor contains register flags, interconnections, arithmetic logic, control logic, and all recognized operation codes. The characteristics of the microprocessor include:

- o Byte-oriented structure
- o 151 opcodes
- o Decimal and binary arithmetic modes
- o Seven addressing modes
- o True indexing
- o Stack pointer
- o Two interrupt levels
- o 64K address range
- o Integral clock circuit
- o Single +5 volt DC power requirement

Figure 1-3 is an illustration of the 6502C CPU Pin Assingments.

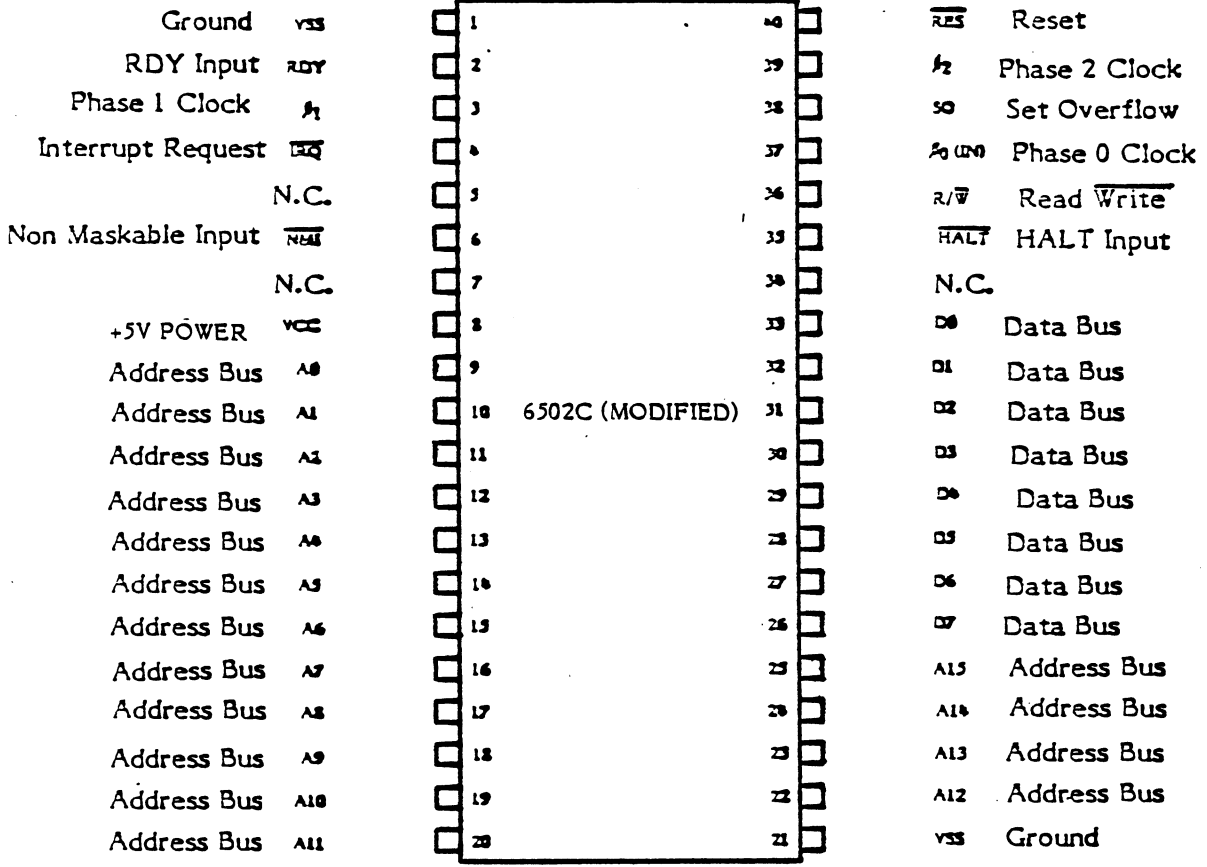

Figure 1-3. 6502C CPU Pin Assignments

Alphanumeric Television Interface Controller (ANTIC)

The ANTIC Display Processor is a custom display microprocessor with an instruction set customized for graphics generation. It also has the ability to control the ADDRESS & DATA bus and RAM Refresh.

Figure 1-4 is an illustration of the ANTIC Display Processor pin assignments.

GROUND	VSS	1	ANTIC	40	D4	Data Bus
Alphanum. Data	AN0	2		39	D5	Data Bus
Alphanum. Data	AN1	3		38	D6	Data Bus
Light Pen	LP	4		37	D7	Data Bus
Alphanum. Data	AN2	5		36	RST	Reset
(SYS RST)	RNMI	6		35	F00	Fast Phase 0 Clock
Interrupt Output	NMI	7		34	00	Phase 0 Clock
Refresh	REF	8		33	D3	Data Bus
HALT	HALT	9		32	D2	Data Bus
Address Bus	A3	10		31	D1	Data Bus
Address Bus	A2	11		30	D0	Data Bus
Address Bus	A1	12		29	02	Phase 2 Clock
Address Bus	A0	13		28	A4	Address Bus
Read/Write	R/W	14		27	A5	Address Bus
Ready Output	RDY	15		26	A6	Address Bus
Address Bus	A10	16		25	A7	Address Bus
Address Bus	A12	17		24	A8	Address Bus
Address Bus	A13	18		23	A9	Address Bus
Address Bus	A14	19		22	A11	Address Bus
Address Bus	A15	20		21	VCC	5V Power

Figure 1-4. ANTIC Display Processor Pin Assignments

Graphic Television Interface Adaptor (GTIA)

The GTIA interfaces with the ANTIC processor on one side and with the video summation circuitry on the other. Its primary task is to generate color and luminance signals from the bit stream it receives from the ANTIC Display Processor. It also processes the Function keys, provides the keyboard "beep" via the TV speaker and monitors controller Trigger lines.

Figure 1-5 is an illustration of the GTIA pin assignments.

Address Bus	A1	1	GTIA	40	A2	Address Bus
Address Bus	A0	2		39	A3	Address Bus
Ground	VSS	3		38	A4	Address Bus
Data Bus	D3	4		37	D4	Data Bus
Data Bus	D2	5		36	D5	Data Bus
Data Bus	D1	6		35	D6	Data Bus
Data Bus	D0	7		34	D7	Data Bus
Trigger 0	T0	8		33	R/W	Read/Write
Trigger 1	T1	9		32	CS	Chip Select 1
Trigger 2	T2	10		31	Lum 3	Luminance Line
Trigger 3	T3	11		30	Φ2	Phase 2 Input
Option	S0	12		29	F00	Clock Out
Start	S1	13		28	OSC	Oscillator Input
Select	S2	14		27	VCC	Power
Keyboard Click	S3	15		26	HALT	HALT
PAL Color Delay	PAL	16		25	CSYNC	Output Sync
Color Delay	CADJ	17		24	LUM 2	Luminance 2 Output
Alphanum. Data 0	AN0	18		23	LUM 1	Luminance 1 Output
Alphanum. Data 1	AN1	19		22	LUM 0	Luminance 0 Output
Alphanum. Data 2	AN2	20		21	COL	Color

Figure 1-5. GTIA Pin Assignments

POT KEYboard Integrated Circuit (POKEY)

The POKEY is a custom Large Scale Integrated circuit (LSI) chip. It is used for audio generation, Serial Input/Output (SIO) Data and Clocks, POT Controller interface scan, and keyboard scan.

Figure 1-6 is an illustration of the POKEY pin assignments.

Ground	VSS	1		40	D2	Data Bus
Data Bus	D3	2		39	D1	Data Bus
Data Bus	D4	3		38	D0	Data Bus
Data Bus	D5	4		37	AUDIO	Audio Out
Data Bus	D6	5		36	A0	Address Bus
Data Bus	D7	6		35	A1	Address Bus
Phase 2 Clock	Ø2	7		34	A2	Address Bus
Pot Scan	P6	8		33	A3	Address Bus
Pot Scan	P7	9		32	R/W	Read/Write
Pot Scan	P4	10		31	CS1	Chip Select
Pot Scan	P5	11		30	CS0	Chip Select
Pot Scan	P2	12		29	IRQ	Interrupt Request
Pot Scan	P3	13		28	SOD	Serial Output Data
Pot Scan	P0	14		27	ACLK	Serial Output Clock
Pot Scan	P1	15		26	BCLK	Bidirectional Clock
Keyboard Response	KR2	16		25	KRI	Keyboard Response
5 V Power	VCC	17		24	SID	Serial Input Data
Keyboard Scan	K3	18		23	K0	Keyboard Scan
Keyboard Scan	K4	19		22	K1	Keyboard Scan
Keyboard Scan	K3	20		21	K2	Keyboard Scan

Figure 1-6. POKEY pin assignments

Peripheral Interface Adaptor (PIA)

The PIA is a general purpose Input/Output (I/O) chip. It monitors the X-Y controller interfaces and the SIO control lines. In certain applications it may control the MMU logic.

Figure 1-7 is an illustration of the PIA assignments.

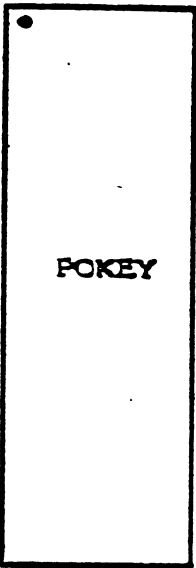
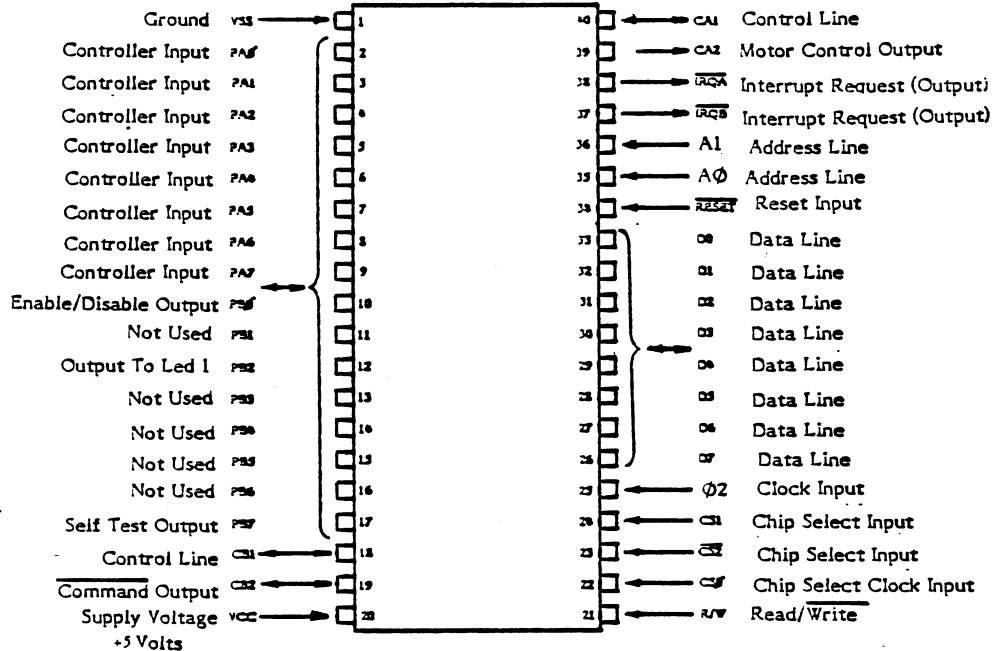

Figure 1-7. PIA Pin Assignments

MEMORY (ROMS AND DRAMS)

O.S. ROM

The 600XL operating system is resident in one 16K X 8 ROM. The ROM address inputs are from CPU address lines A0 through A13. The chip selects from the address decoding circuitry and generates data on CPU data lines D0 through D7. The ROM requires a power input of +5 volts.

BASIC ROM

The Atari 600XL has built-in Atari BASIC (Rev. B) residing in an 8K X 8 ROM. This is equivalent to having an Atari BASIC cartridge permanently plugged into the console. Any cartridge plugged into the computer, takes precedence over the built-in BASIC.

DRAMS

The 600XL Dynamic Random Access Memories (DRAMS) consist of two 16K X 4 DRAMS. 16K of RAM is directly available, expandable to 64K by the 1064 48K Memory Expansion Module that plugs into the parallel bus interface (PBI).

MEMORY MANAGEMENT UNIT (MMU)

The memory management unit (MMU) address decoding circuitry consists of a PAL (Programmable Array Logic) I.C., one 3 to 8 decoder and a few gates. The input to the circuitry includes the address lines A8 through A15 as well as control signals, such as ROM enable (from PIA) and DRAM refresh from ANTIC. Some of the most important outputs of this circuitry include select signals for the GTIA, POKEY, PIA, OS ROM, DRAMS, BASIC and cartridge.

RF MODULATOR

The RF modulator accepts the composite video from the video summation circuitry and the mono-aural audio signals and produces a modulated signal suitable for the television.

With a 75 Ohm termination, the modulated signal has the following characteristics:

Maximum Voltage: 2MV
Minimum Voltage: 1MV

Audio Sound Carrier Frequency: 4.5 MHz

Frequency Response:

Channel 2 -

Band: 6 MHz
Video Carrier: 55.25 MHz
Audio Carrier: 59.75 MHz

Channel 3 -

Band: 6 MHz
Video Carrier: 61.25 MHz
Audio Carrier: 65.75 MHz

POWER SUPPLY

The power supply connector is a 7-pin DIN connector.

The Atari 600XL has an external power supply that accepts 110 VAC (nominal) from the power lines and provides +5 VDC output (+/- 2%). The maximum rating for the supply is + 5 volts and 1.5 amps.

Figure 1-8 is an illustration of the power supply connector pin assignments.

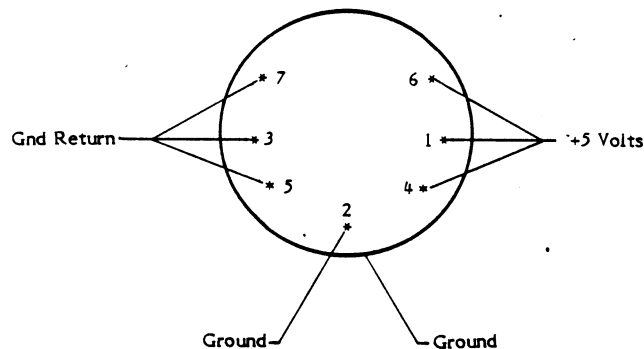

Figure 1-8. Power Supply Pin Assignments
(Looking Toward Computer)

SYSTEM INTERFACE

The 600XL provides the following interfaces:

- o Serial input/output (SIO)
- o Keyboard Interface
- o Controller Jacks
- o Cartridge Interface
- o Parallel Bus Interface (PBI)

SERIAL INPUT/OUTPUT (SIO) INTERFACE

The Atari 600XL communicates with peripheral devices via an asynchronous serial port (19.2K Baud rate max.). Data is transmitted and received as eight bits of serial data. LSB is sent first preceded by a logic zero start bit and succeeded by a logic one stop bit. The serial data out is transmitted or received as positive logic. The serial data out line always assumes its new state when the serial clock out line goes high. Clock out goes low in the center of data out.

The bus protocol specifies that all commands must originate from the computer and that peripherals present data on the bus only when commanded to do so. Every bus operation goes to completion before another bus operation is initiated. An error detected at any point in the bus operation aborts the entire sequence. A bus operation consists of the following elements:

- Command Frame (From Computer)
- Command Frame
 - 1) Data Send
 - 2) Data Receive
 - 3) Immediate (No Data-Command Only, i.e., status)
- Acknowledge Frame (From Peripheral)
- Optional Data Frame (To Or From Computer)
- Complete Frame (From Peripheral)

Figure 1-9 shows pin assignments for the SIO connector.

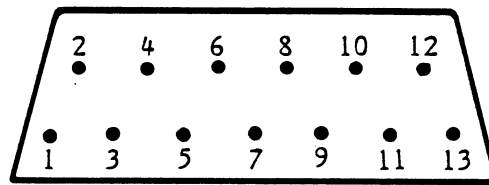

- | | |
|-----------------|-------------------|
| 1. Clock Input | 8. Motor Control |
| 2. Clock Output | 9. Proceed |
| 3. Data Input | 10. +5/Ready |
| 4. Ground | 11. Audio Input |
| 5. Data Output | 12. Not Connected |
| 6. Ground | 13. Interrupt |
| 7. Command | |

Figure 1-9. SIO Connector Pin Assignments

KEYBOARD INTERFACE

The keyboard has 55 alphanumeric keys (including special characters and controls), a spacebar, which interface thru U22 and U23 Keyboard Sense/Scan Decoders, four function keys, and a RESET key.

CONTROLLER JACK INTERFACES

The 600XL provides two controller jack interfaces. Both are functionally and electrically identical. The controller jacks are 9-pin D-type male connectors.

Figure 1-10 shows the pin assignments for the 9-pin connectors.

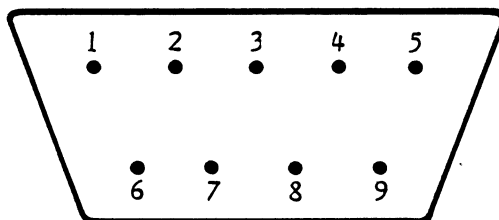

- | | |
|-----------------------------|--------------------------|
| 1. (Joystick) Forward Input | 6. Trigger Input |
| 2. (Joystick) Back Input | 7. +5 volts |
| 3. (Joystick) Left Input | 8. Ground |
| 4. (Joystick) Right Input | 9. A Potentiometer Input |
| 5. B Potentiometer, Input | |

Figure 1-10. Controller Jack Pin Assignments

CARTRIDGE INTERFACE

The cartridge interface connects cartridges to the computer with a 30-pin connector.

The Atari 600XL has Revision B of Atari BASIC built-in. This is equivalent to having a BASIC cartridge "permanently" plugged into the console. When any cartridge is plugged into the computer, it takes precedence over the built-in BASIC. This is a function of hardware. When no cartridge is plugged in, the hardware enables the built-in BASIC.

Figure 1-11 illustrates the pin assignments of the cartridge connector.

$\overline{S4}$	1	A	RD4
A3	2	B	GND
A2	3	C	A4
A1	4	D	A5
A0	5	E	A6
D4	6	F	A7
D5	7	H	A8
D2	8	J	A9
D1	9	K	A12
D0	10	L	D3
D6	11	M	D7
$\overline{S5}$	12	N	A11
+5V	13	P	A10
RD5	14	R	R/ \overline{W}
\overline{CCNTL}	15	S	B0Z

CONSOLE BOTTOM

CONSOLE TOP

Figure 1-11. Cartridge Connector Pin Assignments

PARALLEL BUS INTERFACE

The parallel bus interface (PBI) provides an un-buffered, direct connection to the address, data and control signals shown below. It could be used to interface peripherals, parallel bus devices and external applications.

Figure 1-12 illustrates the pin assignments of the parallel bus interface.

Parallel Bus Specification

GROUND	GND	1	2	EXTSEL' (EXTERNAL SELECT)
(ADDRESS OUTPUT)	A0	3	4	A1 (ADDRESS OUTPUT)
(ADDRESS OUTPUT)	A2	5	6	A3 (ADDRESS OUTPUT)
(ADDRESS OUTPUT)	A4	7	8	A5 (ADDRESS OUTPUT)
(ADDRESS OUTPUT)	A6	9	10	GND
(ADDRESS OUTPUT)	A7	11	12	A8 (ADDRESS OUTPUT)
(ADDRESS OUTPUT)	A9	13	14	A10 (ADDRESS OUTPUT)
(ADDRESS OUTPUT)	A11	15	16	A12 (ADDRESS OUTPUT)
(ADDRESS OUTPUT)	A13	17	18	A14 (ADDRESS OUTPUT)
GROUND	GND	19	20	A15 (ADDRESS OUTPUT)
DATA BI-DIRECTIONAL	D0	21	22	D1 (DATA-BI-DIRECTIONAL)
DATA BI-DIRECTIONAL	D2	23	24	D3 (DATA-BI-DIRECTIONAL)
DATA BI-DIRECTIONAL	D4	25	26	D5 (DATA-BI-DIRECTIONAL)
DATA BI-DIRECTIONAL	D6	27	28	D7 (DATA-BI-DIRECTIONAL)
GROUND	GND	29	30	GND GROUND
PHASE 2 CLOCK-OUTPUT	B02	31	32	GND GROUND
N/C	RESERVED	33	34	RST' RESET OUTPUT
INTERRUPT REQUEST INPUT	IRQ	35	36	RDY READY INPUT
N/C	RESERVED	37	38	EXTENB EXTERNAL DECODER-OUTPUT
N/C	RESERVED	39	40	REF' REFRESH-OUTPUT
COLUMN ADDRESS-OUTPUT	CAS'	41	42	GND GROUND
MATH PACK DISABLE-INPUT	MPD'	43	44	RAS' ROW ADDRESS STROBE (OUTPUT)
GROUND	GND	45	46	LR/W' LATCHER READ/WRITE-OUTPUT
N/C	RESERVED	47	48	RESERVED N/C
AUDIO IN	AUDIO	49	50	GND GROUND

Figure 1-12. PBI Connector Pin Assignments
(Looking into the Computer)

SECTION 2

TESTING AND TROUBLESHOOTING

OVERVIEW

This section describes the procedures available for testing and troubleshooting the 600XL. They are:

- o Self Test
- o super SALT Diagnostic Cartridge

EQUIPMENT NEEDED

- o 600XL Computer console with accessories
- o TV set, properly adjusted
- o super SALT Diagnostic Cartridge
- o super SALT Extended Hardware and accessories

SELF TEST FEATURES

The Self Test feature allows minimal testing of the following components:

- o Memory - RAM, ROM and ANTIC
- o Audio/Visual - ANTIC, GTIA, and POKEY
- o Keyboard - POKEY and ANTIC

NOTE: Remove any cartridge from the unit.

To enter the testing sequence, press and hold the OPTION key while the console is turned on. The Self Test menu screen will appear.

To exit the test, press the SYSTEM RESET key, the Basic Ready prompt will appear on the screen.

NOTE: Pressing the HELP key has no effect in any situation, except possible future application programs and as an exit from out individual test to return to Self Test menu.

Procedure:

1. Connect the computer console to TV set as shown in owner's manual.
2. Turn on TV set.
3. Press and hold the OPTION key as the computer is turned on until the Self Test menu appears.
4. The Self Test Menu displays four options:
 - o Memory
 - o Audio Visual
 - o Keyboard
 - o All Test

Press the SELECT key to move the selection indicator until you reach the desired test.

Press the START key to begin the test.

CAUTION: Self Test will not go into the Attract Mode. Do not leave Self Test screens on for any length of time (maximum seven minutes), since screen burning can occur.

DESCRIPTION OF SELF TESTS

MEMORY TEST

Purpose: To test the ROM, RAM, and ANTIC chips.

Format: Two long bars display at the top of the screen represent the two 8K ROMs in the system. Below them is one row with sixteen blocks, each representing the 1K of RAM. When either ROM or RAM is being tested, the corresponding bar segment color is white. If the ROM or RAM tests good, the bar color changes to light green. If the ROM or RAM tests defective, the color changes to red. Once a ROM or RAM has been tested and found defective the bar or specific block remains red and the memory is not tested again on subsequent test passes.

The MEMORY TEST continues testing until either the HELP or RESET key is pressed.

NOTE: If RESET is used to exit a test, the OS will return to Basic not the Self Test. You must then press and hold OPTION and power up the console as before.

AUDIO VISUAL TEST

Purpose: To test the ANTIC and POKEY chips.

Format: The screen displays a music staff and treble clef. A sequence of six tones sound and the corresponding note shows on the staff. The tune plays sequentially from channel one through channel four. The channel number changes for each according to the sound channel in use. Voice numbers 1-4 under the staff and treble clef indicate the channel in use. There is a slight pause between each voice. A fault is indicated by a note appearing on the screen without any sound and vice versa.

The AUDIO VISUAL TEST continues testing until either the HELP or RESET key is pressed.

KEYBOARD TEST

Purpose: To test the POKEY, ANTIC and ROM chips

Format: A full keyboard is displayed on the screen. Press each keyboard key and the corresponding key on the screen changes to inverse video and a tone sounds. It should change back to the original color when the key is

released. NOTE: The control and shift keys change only when pressed at the same time as another key. The display for both keys will change to inverse video and then back. As each key (except RESET, HELP & BREAK) is pressed, a tone is generated.

ALL TESTS

All of the Self Tests are executed one after another until either the HELP or RESET key is pressed.

NOTE: When ALL TESTS is executing, the MEMORY TEST and the AUDIO VISUAL TEST exit after one complete test cycle. KEYBOARD TEST during ALL TESTS is software controlled. No operator input is required.

SUPER SALT FEATURES

Overview

CPS super SALT Kit (FK100331) consists of two items: 1) CPS super SALT Extended Hardware (FA100332) which serves as an analog to digital converter and data switching unit; and 2) CPS super SALT cartridge (FD100335) which contains the software.

The super SALT Extended Hardware tests voltage, SIO, and the controller ports. It loops digital data from one controller port to another and checks the results, or converts analog signals and levels to digital data and returns the data for analysis via the SIO port to the unit under test.

The software contained in the super SALT cartridge is designed to test all areas of the system: MPU, RAM, ROM, SIO port, Controller ports, ANTIC, GTIA, POKEY and Keyboard, as well as Video and Audio Logic.

Five functional divisions in the software menu include:

- o PERFORMANCE TEST
- o INDIVIDUAL TEST
- o EXTENDED UNIT TESTS
- o CHANGE TEST OPTS
- o SHOW ERR SUMMARY

Each of these functions contains another menu to further control and/or tailor test selections. A brief discussion of each test follows.

PERFORMANCE TEST

Performance Testing is the sequential execution of predetermined test routines that cannot be changed. Once started, all tests execute unless BREAK or RESET is depressed. This action halts testing

EXTENDED UNIT TEST

Extended Unit Testing is much like Performance Testing in that it is a sequence of tests. The difference is that the sequence to be executed may be added to or deleted from and the order rearranged. Thus, the technician may tailor the testing to specific problems.

INDIVIDUAL TEST

Individual Testing allows a specific program to be executed in order to test a suspect function.

CHANGE TEST OPTS

The Change Test Opts feature allows you to change testing parameters for further tailoring of any of the test procedures. You may select any of the following features in any combination:

- o Continuous or single pass testing (all tests).
- o Testing Sequence (when applicable) sequential or random.
- o Display time, two to twenty seconds in two second intervals. You can also select an infinite display duration called "RTN", which loops through a test or tests until you press RETURN.
- o Test Group, selection control of the programs which run under the Extended Unit Testing option.

SHOW ERR SUMMARY

The Show Err Summary screen displays a tabulation of errors detected in each test executed.

- NOTE:
1. All counters in Error Summary are reset if SYSTEM RESET is pressed.
 2. For the Executive Menu, OPTION displays the selected menu. SELECT moves the pointer (title turns black) to a new selection and BREAK returns to previous menu.
 3. BREAK returns to previous menu during any testing. Be patient. Some test must complete before the software recognizes the BREAK key. INDIVIDUAL TESTS, CHANGE TEST OPTIONS and SHOW ERR SUMMARY menus have special instructions (different from other test menus) for execution. NOTE these instructions for proper execution, at the bottom of the display screen.

SUPER SALT TESTING PROCEDURES

Required:

- o super SALT Cartridge (FD100335)
- o Television, properly adjusted
- o 600XL ATARI CPU to be tested
- o super SALT Extended Hardware (FA100332) (See Figure 2-1)

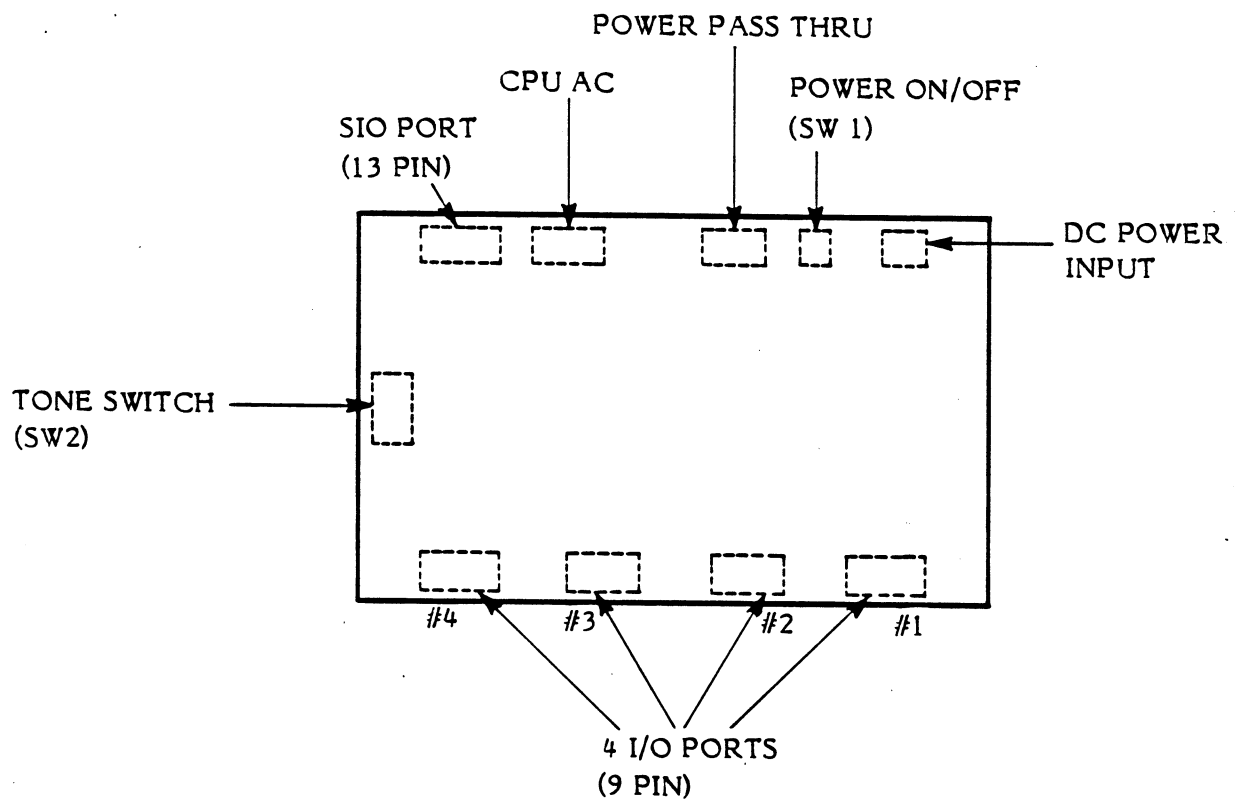

Figure 2-1. Super SALT Extended Hardware

Procedure:

If voltage levels, SIO, 2-way clocks, external audio or controller ports are to be tested, connect the super SALT Extended Hardware (Refer to Figure 2-1). Perform the following functions exactly as described below to connect the super SALT Extended Hardware (SSEH) (FD100332).

1. Connect the I/O Ports (9-Pin) between the computer and the extended hardware as directed below:
 - a. Computer controller PORT 1 to SSEH Port 4.
 - b. Computer controller PORT 2 to SSEH Port 3.
 2. Connect the SIO Port (13-Pin) on SSEH to Computer PERIPHERAL Port.
 3. Connect the Computer Power Adaptor, per instructions in the Owner's Manual.*
 4. Connect the SSEH Power Adaptor (C010472) to the SSEH.*
- * = NOTE: The 600XL and the Super SALT Extended Hardware must be powered by their respective power supply.
5. Tone Switch set toward controller ports for 400/800 and away from ports for all other CPUs.

Connect the television. Insert the super SALT cartridge and turn on the power. The screen displays the Title Screen (See Figure 2-2).

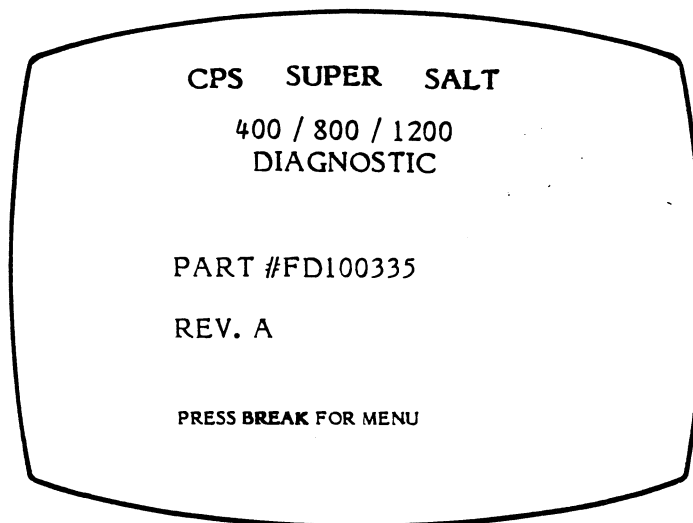

Figure 2-2. Title Screen

Depress the BREAK key to continue, the screen displays the super SALT Executive Menu (See Figure 2-3).

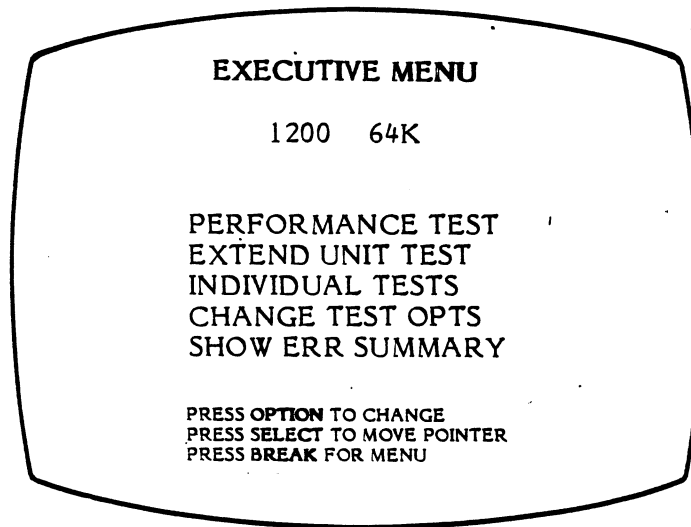

Figure 2-3. Executive Menu Screen

PERFORMANCE TEST

The Performance Test is automatically highlighted when super SALT initializes. This must be the first test run. The Performance Test does require the extended hardware.

Press the Option key to show the main menu. Verify that the extended hardware is connected, I/O cabling is installed correctly and power is on.

Press START, the Performance Test Screen is displayed (See Figure 2-4).

2-WAY CLOCK TEST

As shown on the screen (See Figure 2-5), if tones are heard the test passes. If tones are not heard, verify the following.

Verify:

- TV volumn is up
- Extended Hardware is properly connected
- Extended Hardware is powered up.
- Extended Hardware Tone Switch is set correctly

Execute the Performance Test again. If failure persists go to the Individual Test Menu to loop on test for scoping. If all signals are found, replace Pokey I.C. - U20.

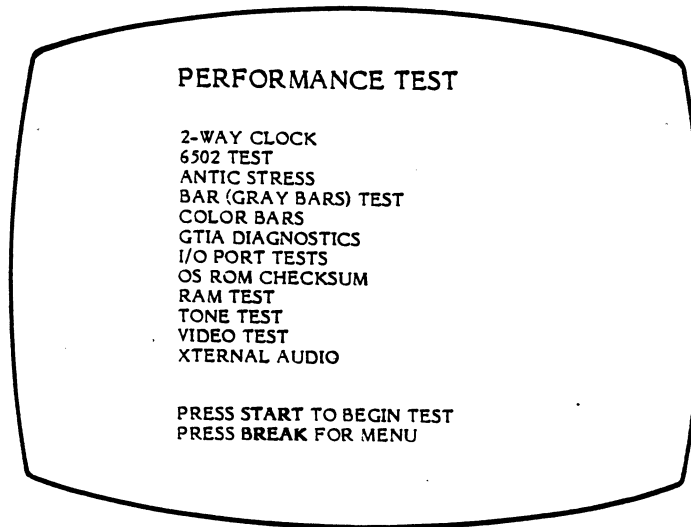

Figure 2-4. Performance Test Screen

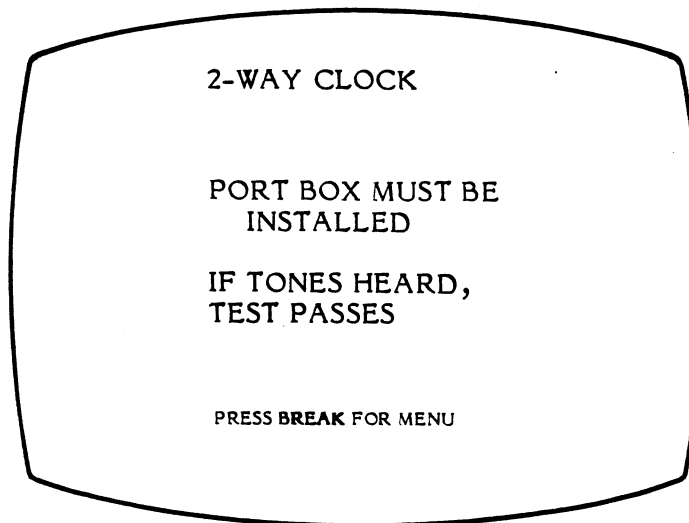

Figure 2-5. 2-Way Clock Screen

6502 TEST

The 6502 Test screen (See Figure 2-6), is the next test performed. A single pass executes 100 cycles before displaying this screen. One cycle is a complete execution of all 151 operation codes performed by the 6502 CPU.

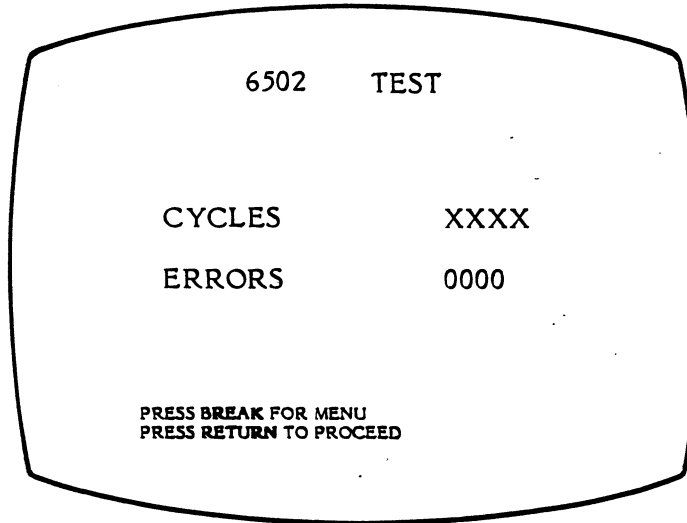

Figure 2-6. 6502 Test Screen

One of four conditions will exist as a result of 6502 Test execution. They are:

1. The test passes, and the screen display shows the number of complete cycles, or
2. The test fails due to an error detected in the low bank of RAM, reporting a RAM error (verify with RAM Test), or
3. The test fails due to an incorrect result detected during the attempted execution of a CPU instruction, shown on SHOW ERR SUMMARY, or
4. The test never completes due to a faulty CPU (or other associated component) causing the CPU to execute an illegal instruction, and potentially ending up in an undefined execution mode usually a "lock-up".

Failures of type 2 should be verified by the RAM Test. If RAM Test does not fail, replace 6502 IC - U10.

For failures of types 3 or 4 - replace 6502 IC - U10.

ANTIC STRESS TEST

The purpose of the ANTIC Stress Test (See Figure 2-7) is to assure that all possible display modes of the ANTIC are functioning. This test is operator interactive. The only way to determine whether the unit is functioning correctly is to judge the correctness of the display. If its physical appearance does not match that shown, there may be a problem with one or more display modes of the ANTIC.

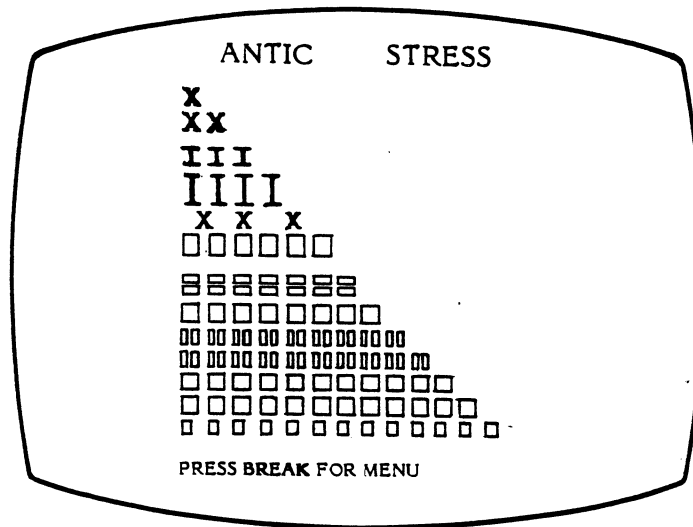

Figure 2-7. ANTIC Stress Screen

The top of the screen has the title, ANTIC Stress, first in capital letters and switches to lower case. The top X appears as an X then as an inverse X. The fourth row of characters, four Capital I's, scroll upward and disappear. Then scroll downward back onto the display. The fifth row of characters, three X's, scroll to the right. As they scroll a fourth X appears from the left until it is a full character. The row then scrolls to the left until only three X's are on the screen again. All other rows of blocks must have the shape indicated, must be properly spaced and separated. The bottom of the screen has the instructional message with the word BREAK flashing on and off. All items mentioned must be present and correctly displayed. Color is not important, only function. Any failure above indicates a faulty ANTIC.

BAR TEST

This test verifies that the GTIA is generating four LUM bits (LUM0-3).

The screen shown below is a display of the Gray Bar Test (See Figure 2-8). The screen is divided into eight equal sized horizontal bars. The bar at the top of the screen should be black and subsequent bars should progress to white at bar eight. The bars should lighten in even shades. The screen should be steady and unchanging. These lines may have minor glitches at their edges. A thin white line should always appear just over the top (black) bar. No color should appear anywhere on the screen. The areas above the top (black) bar and below the bottom (white) bar are of no importance to this test. This test should be left on for at least 10 seconds to ensure that there is no "flashing" of color or shifting of the gray bars.

Missing bars, bars of the same exact shade, colored bars or more than eight bars indicate a faulty GTIA.

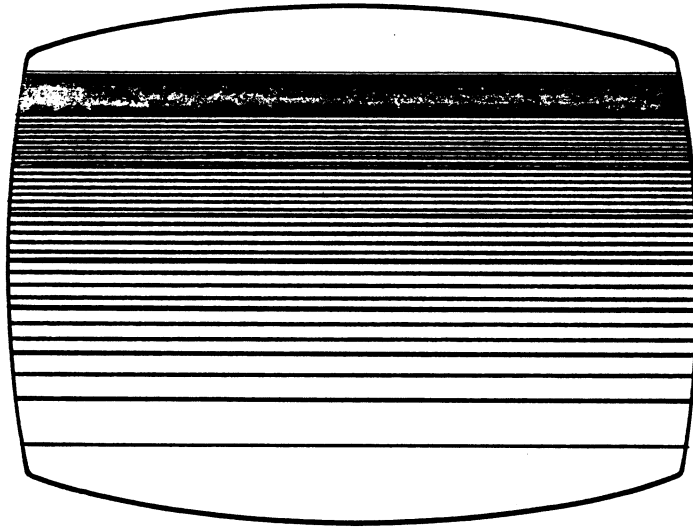

Figure 2-8. Bar Test Screen

COLOR BARS

This test verifies and allows for adjustment of the color circuitry. The screen shown below is a black and white representation of how your television display screen should appear (See Figure 2-9).

A 15-color rainbow scale is displayed above the reference bar with a single color bar below. The color bars directly above and below the reference bar should be the same color (golden rod). If not, proper adjustment of a variable resistor makes the color bars above and below the gray reference bar identical thus adjusting the color frequency of the console to the proper setting.

The operator should verify proper operation of the unit by making this adjustment with the unit displaying consistent color within the entire span of each bar on the screen. Minor glitches on the edges of the color bars are acceptable.

Any missing bars or lack of color indicate failures. Failures in order of importance are:

1. Color adjustment - Adjust R43
2. Faulty GTIA
3. Faulty ANTIC
4. Bad or incorrect crystal - Y1 (NTSC 3.579545 MHz, PAL 3.546894 MHz)

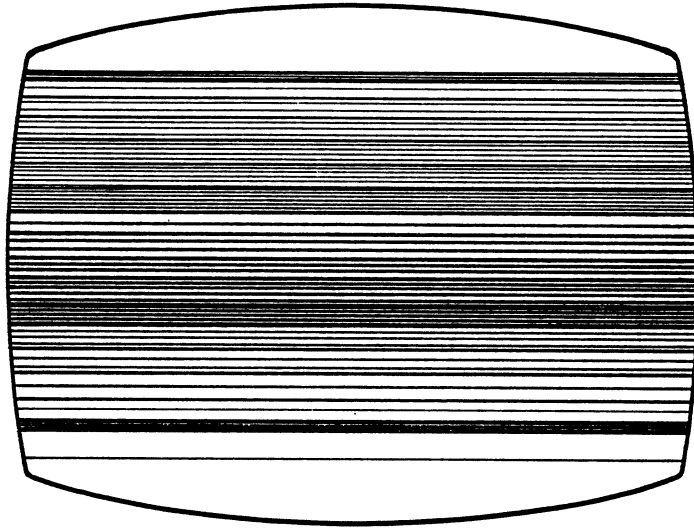

Figure 2-9. Color Bar Screen

GTIA DIAGNOSTICS

NOTE: The description below is lengthy. It is suggested that the technician first watch the GTIA Diagnostic function several times using Individual Test Mode. Then read this analysis procedure.

The three GTIA Diagnostic Screens (See Figures 2-10 thru 2-12) which follow are black and white representations of your television display.

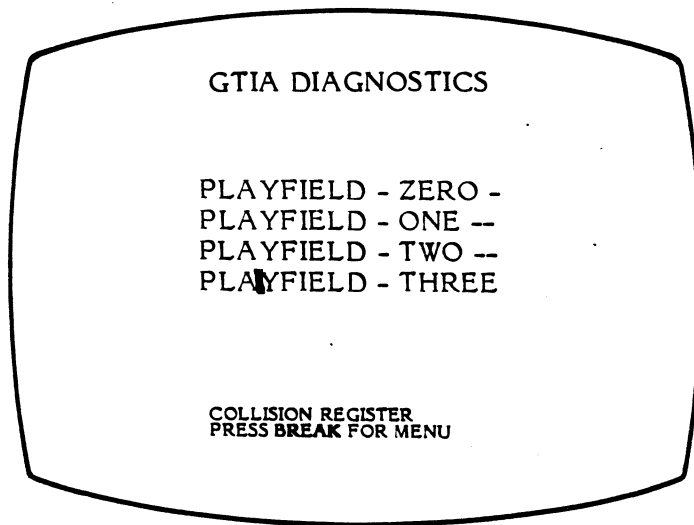

Figure 2-10. GTIA Diagnostic Screen (Part 1)

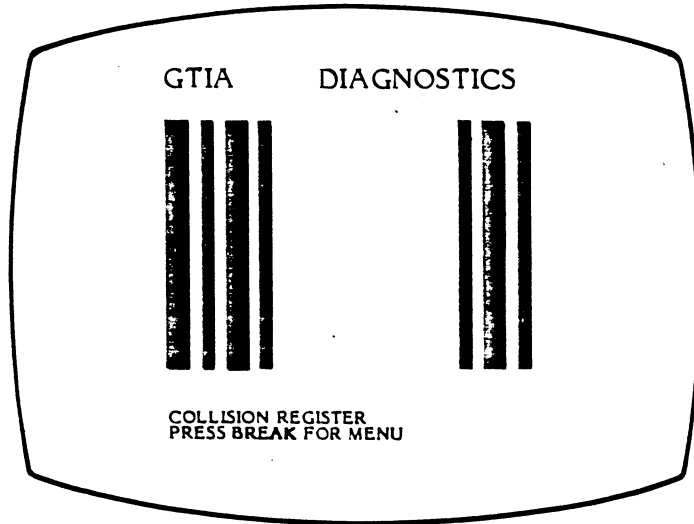

Figure 2-11. GTIA Diagnostic Screen (Part 2)

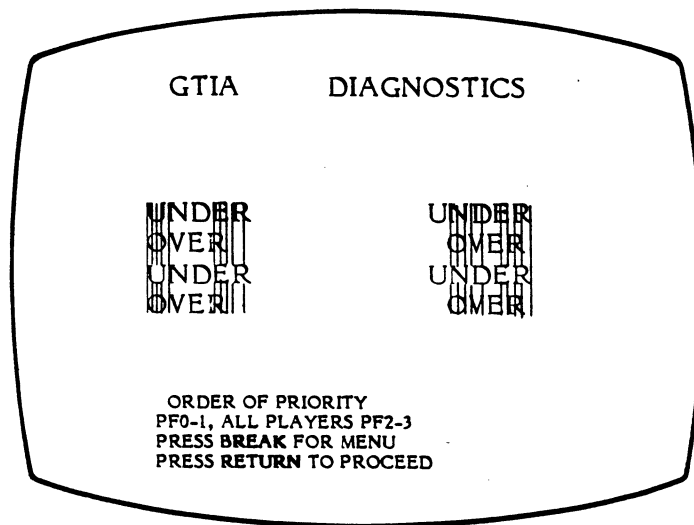

Figure 2-12. GTIA Diagnostic Screen (Part 3)

Part 1

There are four horizontal bars formed on the screen by the words PLAYFIELD ZERO, ONE, TWO, and THREE (Refer to Figure 2-10).

Moving in between the horizontal bars, evenly distributed across the screen, are two sets of rectangles. The first rectangle is formed by players 1 through 4. The second rectangle is formed by missiles 1 through 4.

All of the player-formed figures should be the same size. The missile-formed figures will vary in size on the screen.

This character formation verifies the capability of the GTIA to control the size of the players and missiles correctly. The players are not actually the same size, even though they appear as though they are. This also verifies capability of the GTIA to move missiles and players through the playfields, and detect collisions between players and missiles.

Part 2

There are two sets of four vertical bars (Refer to Figure 2-11). The narrow bars are missiles, the wide bars are players. Both types of bars are rotated through their respective sets. This tests the capability of GTIA to detect collisions on a non-playfield type of operation with multiple players.

Part 3

There are two sets of words, UNDER, OVER, UNDER, OVER (from top to bottom) (Refer to Figure 2-12). These sets of words are striped with thin black bars running vertically top to bottom. The bars should be under the word UNDER and over the word OVER as indicated. Note the text window at bottom of the screen identifies the particular player, missile, playfield combinations in use.

Any failure indicates a faulty GTIA. All test must function properly.

I/O PORT TESTS

NOTE: Must have Extended Hardware connected and operational.

The screens shown below are black and white representations of your television displays (See Figure 2-13 and 2-14).

The following tests are performed:

- a. Voltage levels on each of the ports +5V, ground.
- b. Ability of any and all of the I/O ports to act as an input or as an output.
- c. Exercises the trigger lines in each port.
- d. Exercises the pot lines in each port.
- e. Test the motor control line, the command line, the interrupt line of the serial port and serial input and output data lines.
- f. Verifies the capability of the unit to communicate in ASYNC mode with peripherals at baud rates of 300, 600, 1200, 2400, 4800, 9600, 19200 and synchronous at 19200.

VOLTAGE		TEST	
P1 + =	5.00	P1 - =	0.00
P2 + =	5.00	P2 - =	0.00
P3 + =	.	P3 - =	.
P4 + =	.	P4 - =	.
S5 + =	5.00	GND - =	0.00
MC + =	4.00	MC - =	0.00
V1 + =	.	V1 - =	.
12 + =	.		

PRESS(RETURN) TO PROCEED

Figure 2-13. I/O Port Tests Screen (Voltage Test)

I/O TESTS DONE

VOLTAGE - CURRENT
PIA PORTS
SIO PORT
TRIGGER LINES
POT LINES
TIMERS

PRESS BREAK FOR MENU

Figure 2-14. I/O Port Tests Screen (I/O Tests Done)

The screen is cleared. Voltage Test (Refer to Figure 2-13) is displayed along with the voltages found as appropriate to the 600XL. **NOTE:** No current measurements are available at this time. The screen again is cleared and displays in the center, the following list of tests (Refer to Figure 2-13):

VOLTAGE & CURRENT
PIA PORT
SIO PORT
TRIGGER LINES
POT LINES
TIMERS

The test names are white and changed to green at test completion, REGARDLESS of pass or fail conditions. Reference the SHOW ERR SUMMARY Screen, Schematics and Silkscreens for particulars and troubleshooting. **NOTE:** During Voltage/Current testing (Refer Figure 2-13), green values indicate a pass condition and red indicates a failure. Troubleshoot accordingly.

IMPORTANT: All other failures usually indicate a bad PIA or POKEY IC

ALWAYS verify the Extended Hardware hook-up, setting of switches and power on, for any I/O failures. Execute this test again. Excessive failures, ie, all voltages are incorrect may indicate Extended Hardware failure or lack of power.

OS ROM CHECKSUM

Figure 2-15 shown below is the OS ROM Checksum test.

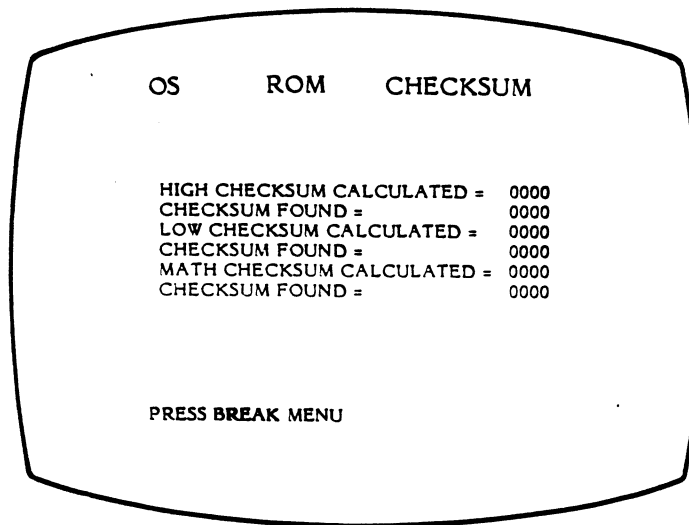

Figure 2-15. OS ROM Checksum Screen

This test reads the OS ROM and performs a checksum calculation. The test then retrieves the stored checksum word from the ROM and compares it to the calculated value. Value differences indicate a failure of the ROM or support circuits.

RAM TEST

Figures 2-16 and 2-17 shown below are the RAM Test screens.

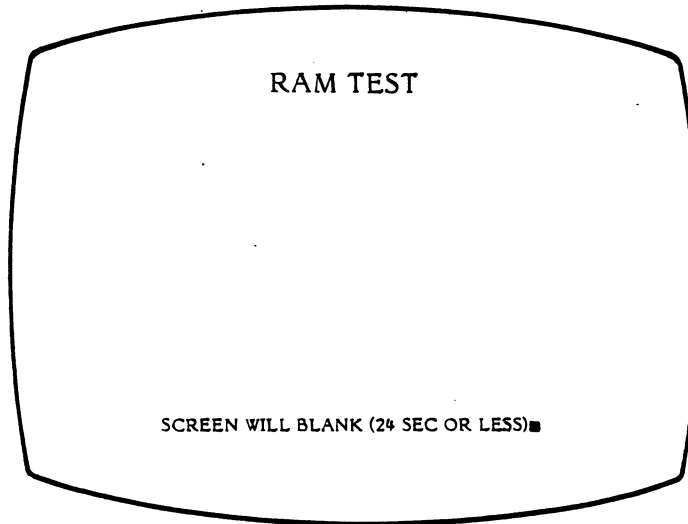

Figure 2-16. RAM Test Screen (Screen 1)

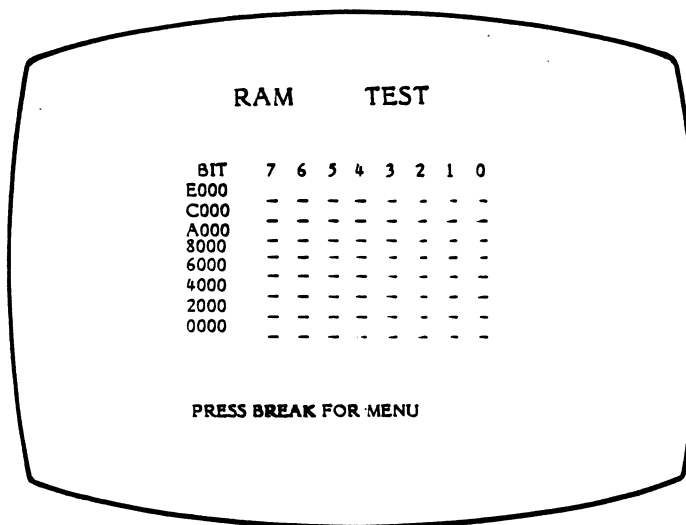

Figure 2-17. RAM Test Screen (Screen 2)

Note the text window in Figure 2-16, the screen goes black for 24 seconds or less while REFRESH testing is performed. The screen then returns with the error summary (Refer to Figure 2-17). Data bit failures on D0-3 are RAM IC U11 and D4-7 are RAM IC U12 regardless of address location or are in the support logic. Data bit failures are indicated by inverse video F.

On any RAM failure refer to HCD Tech Tip #20 and verify that the correct ANTIC revision has been installed. If the proper revision is installed, replace the appropriate RAM IC and retest. If unit still fails, then replace the ANTIC or appropriate support logic.

TONE TEST

Figure 2-18 shown below is the Tone Test screen.

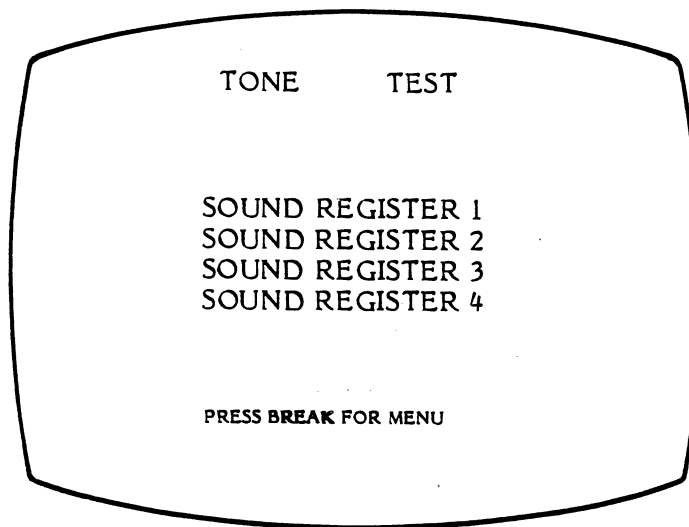

Figure 2-18. Tone Test Screen

The words Sound Register 1,2,3 or 4 are highlighted as each register is tested. The test consists of a sweep of each register from the highest tone to the lowest. Failures are indicated by missing tones. Failures indicate a faulty Pokey I.C., failure of the audio support circuit (U8) or 4.5MHz oscillator misalignment or failure. Adjust 4.5MHz or troubleshoot and repair.

VIDEO TEST

This test verifies the console's ability to generate a video (TV) display. This test also checks for pattern sensitivity of the ANTIC chip.

The screen shown below is the display for Video Test. **NOTE:** This is a black and white representation of a colored screen (See Figure 2-19).

The screen should have a black background with eight vertical bars. Half of the vertical bars should be narrow, and the other half, much wider. A horizontal bar should appear across the top of the screen. From the left to right, the shade of color on the horizontal bar should change. On the right of the bar, two Vs should be displayed, right side up; one in normal video and the other in inverse video.

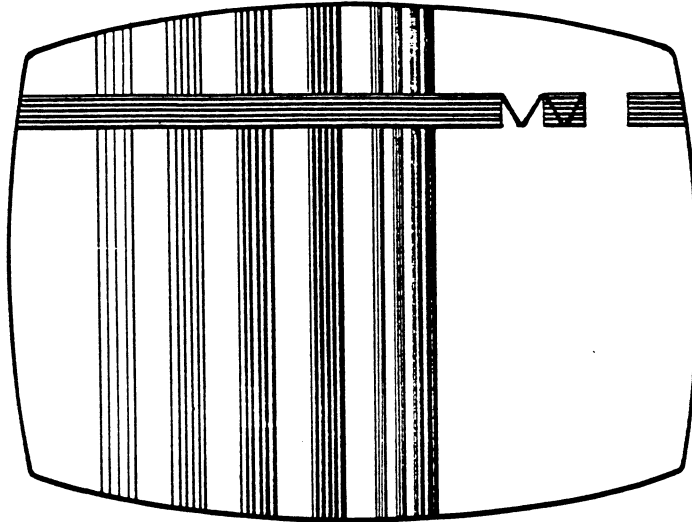

Figure 2-19. Video Test Screen

XTERNAL AUDIO

NOTE: This test requires the Extended Hardware.

Figure 2-20 shown below is the Xternal Audio Menu.

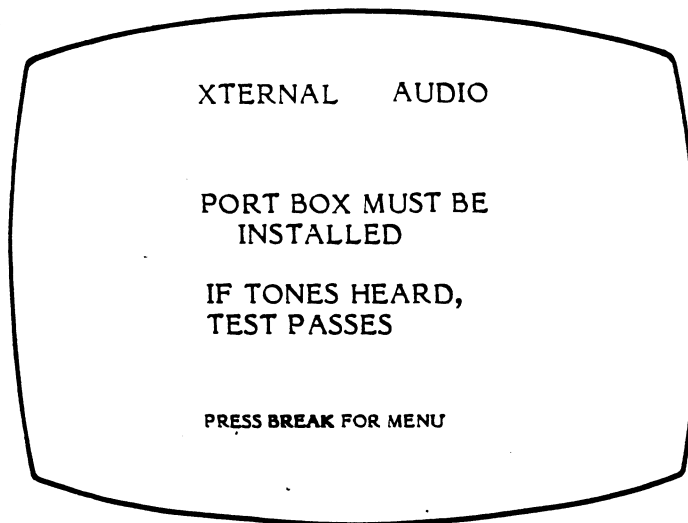

Figure 2-20. Xternal Audio Screen

This test uses the Extended Hardware to simulate external audio as produced by the cassette recorder or other external audio device. If tones (a short melody) are heard, the test passes. If not, failure is probably the POKEY IC. Other possible failures are as follows:

- 1) TV Volume
- 2) 4.5MHz Oscillator adjustment
- 3) Sound mixer, IC U8 and support circuitry

The PERFORMANCE TEST menu is returned to the screen, this ends the PERFORMANCE TEST. If all tests pass, the unit is satisfactory. If the unit fails any of the tests,* use the INDIVIDUAL TESTS along with the CHANGE TEST OPTS to troubleshoot the faulty circuit.

*Press BREAK to access EXECUTIVE MENU screen.

INDIVIDUAL TESTS

NOTE: Only the tests not previously discussed are shown. Reference PERFORMANCE TEST for tests not shown here.

Individual tests discussed earlier allows the technician to execute a particular test indefinitely and for most test control the display time. The details of control are shown in EXTEND UNIT TEST. Press SELECT to move pointer to INDIVIDUAL TESTS. Press OPTION to display menu (See Figure 2-21). Note instructions at bottom of menu.

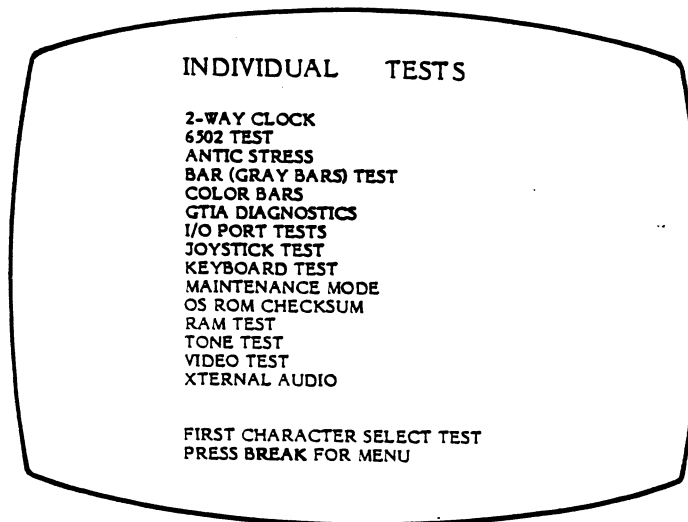

Figure 2-21. Individual Tests Menu Screen

JOYSTICK TEST

Figure 2-22 shown below is the Joystick Test Screen.

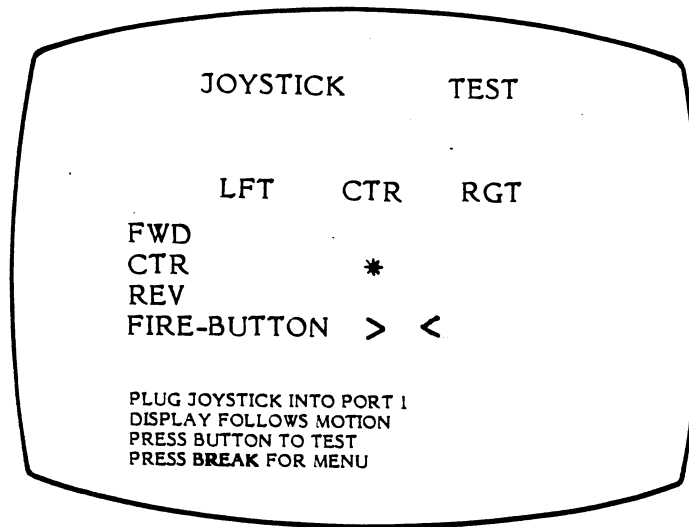

Figure 2-22. Joystick Test Screen

This test is used to verify correct Joystick and Trigger operation. It is assumed that I/O Port Testing is complete and passed. In other words, a working unit.

Insert the Joystick plug into Port 1 on the console. The * (asterisk) displayed on the screen should remain centered. The * should follow the Joystick action as you move the stick. Be sure to test all eight positions and that the Joystick centers when released. As the Trigger is pressed a red * will appear after the words FIRE-BUTTON. Failure of any of these actions indicates a faulty Joystick.

KEYBOARD TEST

This test is a verification test of all keyboard switches and special function switches, ie; OPTION. This is the same test as the Self Test in OS resident. All keys and switches may be verified **except** BREAK and SYSTEM RESET. These are verified by correct operation. SYSTEM RESET should cause the system to reboot and return to Title Screen. BREAK will, as the prompt at the bottom of the screen states, return you to the INDIVIDUAL TESTS menu.

NOTE: The keyboard shown on the screen and in Figure 2-22 is for an ATARI 1200XL TM Computer. Therefore, some keys shown will not function. As each key is pressed, the displayed key will flash to inverse video and a tone is heard. Remember, CONTROL and the SHIFT keys require an additional key be pressed AT THE SAME TIME. Failure of a key display and tone indicates the following possible failures:

- 1) Keyboard key faulty
- 2) Keyboard cable faulty
- 3) Faulty keyboard decoders
- 4) Faulty POKEY IC

Figure 2-23 shown below is the Keyboard Test Screen.

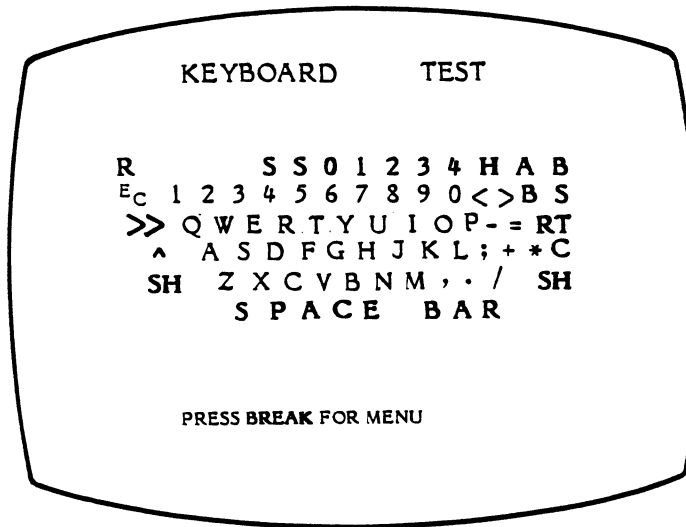

Figure 2-23. Keyboard Test Screen

MAINTENANCE MODE

There is no screen display or if you prefer, a solid black screen. Press any key (except **BREAK** or **SYSTEM RESET**) and a tone is heard. Press any key again. The tone stops.

This mode of operation allows the technician to measure the CH.2 and 4.5MHz carrier frequencies and adjust if necessary.

NOTE: Most state-of-the-art televisions requires exact settings of these frequencies since they incorporate synthesized circuits. It is suggested that a frequency meter be used to measure these frequencies.

CH.2 = 61.25 MHz
Sound Carrier = 4.5MHz

Must use CH.2 due to modulator design.

Once alignment is complete, press any key to produce the tone. This is a verification test of proper alignment. If necessary, adjust television fine tuning to produce clear picture on channel 2.

PADDLE TEST

Figure 2-24 shown below is the Paddle Test Screen.

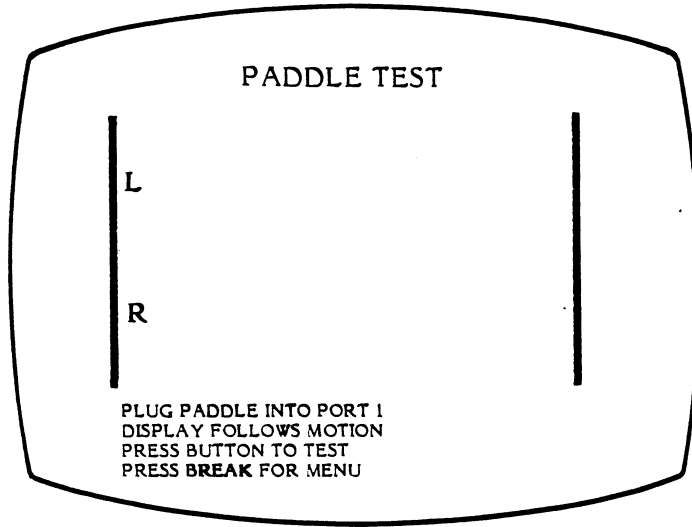

Figure 2-24. Paddle Test Screen

NOTE: This test assumes that the unit is working properly.

Insert the Paddle Controller plug into Port 1 on the console. The displayed characters, L & R, will follow the respective paddle movement as you turn the knob. The Trigger will cause the respective action. Any failure of these actions indicates a faulty Paddle Controller.

This completes the descriptions of all tests that may be performed on the 600XL. Additional testing is suggested using the EXTENDED UNIT TEST in conjunction with the CHANGE TEST OPTS menu for control. For example, the EXTENDED UNIT TEST should be used in CONTINUOUS mode for burn-in testing. Be sure to define test execution, on the CHANGE TEST OPTS menu, to use or not use the Extended Hardware as is appropriate.

CHANGE TEST OPTS & EXTENDED UNIT TEST

Figure 2-25 shown below is the Change Test Opts Screen.

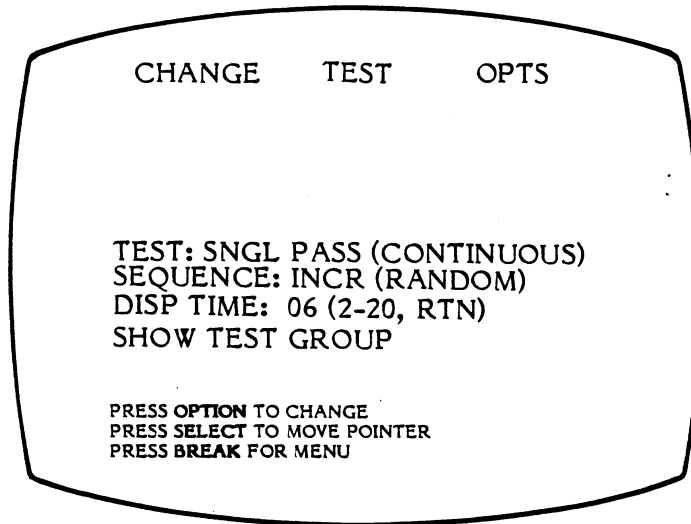

Figure 2-25. Change Test Opts Screen

At the bottom of the screen are instructions for changing test conditions or options.

Press the **OPTION** key to select **SINGLE PASS** or **CONTINUOUS** testing. Press the **SELECT** to move the pointer to **SEQUENCE**. Press **OPTION** to select either **INCR**, as defined by test group, or **RANDOM** which is a random selection of test within the limits of the test group used. Press **SELECT** to move the pointer to **DISP TIME** (display time). Press **OPTION** to select display time in seconds or indefinite. Time values are 2, 4, 6, 8, 10, 12, 14, 16, 18, 20 seconds and **RTN** (**RETURN** key) for indefinite. Very Important: **RTN** option should not be used with any testing except **INDIVIDUAL TESTS** as it halts testing until the **RETURN** key is pressed.

Press **SELECT** to move the pointer to **SHOW TEST GROUP**. Press **OPTION** to display the menu (See Figure 2-26).

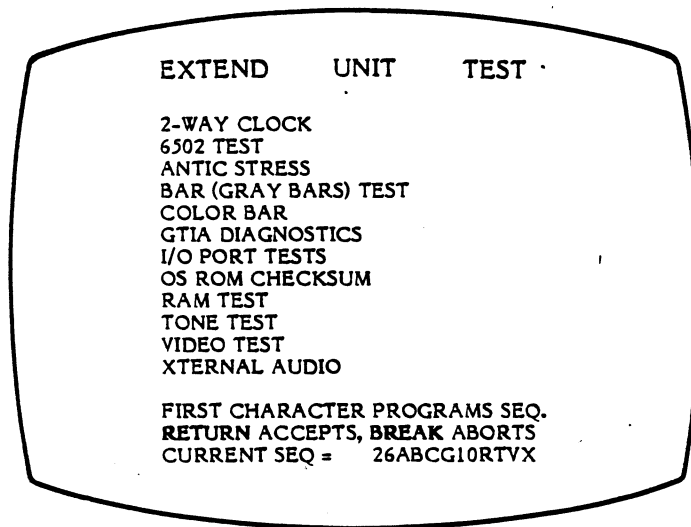

Figure 2-26. Extended Unit Test Screen (Selection)

The bottom of the screen shows the options. The first character of each test selects that test. The RETURN key ends entry of choices and causes diagnostics to use only those tests during EXTEND UNIT TEST. Use the DELETE key to erase choices listed at the bottom of the screen just behind the cursor. **Note:** If 2-WAY CLOCK TEST (2) and 6502 TEST (6) are not desired, DELETE must be used to erase all choices. Then each character except 2 and 6 (ABCGIORTVX) must be pressed followed by a RETURN. Press the BREAK key and return to the EXECUTIVE MENU. Press SELECT to move pointer to the EXTENDED UNIT TEST. Press OPTION to display the EXTENDED UNIT TEST menu shown below (See Figure 2-27).

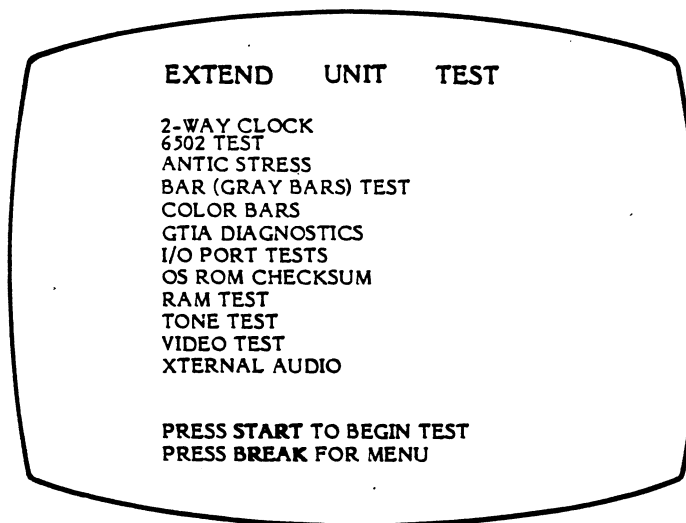
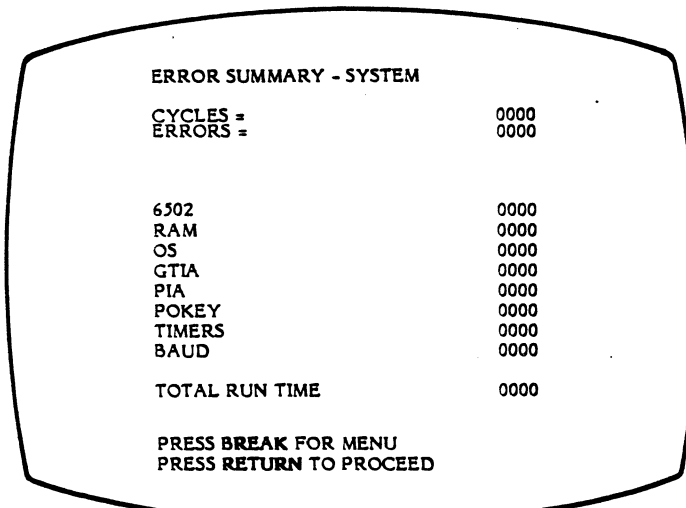

Figure 2-27. Extended Unit Test Screen

Since the CHANGE TEST OPTS menu has been used to select the particular test to be executed, this menu is not altered. However, testing proceeds according to test options definition. This test along with TEST OPTS may be used to execute one or any choices or combination of choices. It may be used to execute a test or tests, continuously to check for a particular intermittent failure or for burn-in.

SHOW ERR SUMMARY

Press BREAK to return to the EXECUTIVE MENU. Press SELECT to move the pointer to the SHOW ERR SUMMARY. Press OPTION to begin display of error summaries shown below (See Figures 2-28 thru 2-36).



ERROR SUMMARY - SYSTEM	
CYCLES =	0000
ERRORS =	0000
6502	0000
RAM	0000
OS	0000
GTIA	0000
PIA	0000
POKEY	0000
TIMERS	0000
BAUD	0000
TOTAL RUN TIME	0000
PRESS BREAK FOR MENU	
PRESS RETURN TO PROCEED	

Figure 2-28. System Error Summary Screen

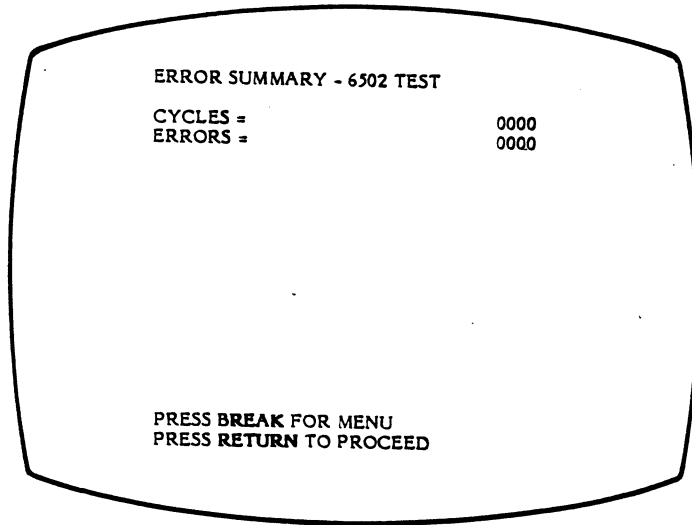

Figure 2-29. 6502 Error Summary Screen

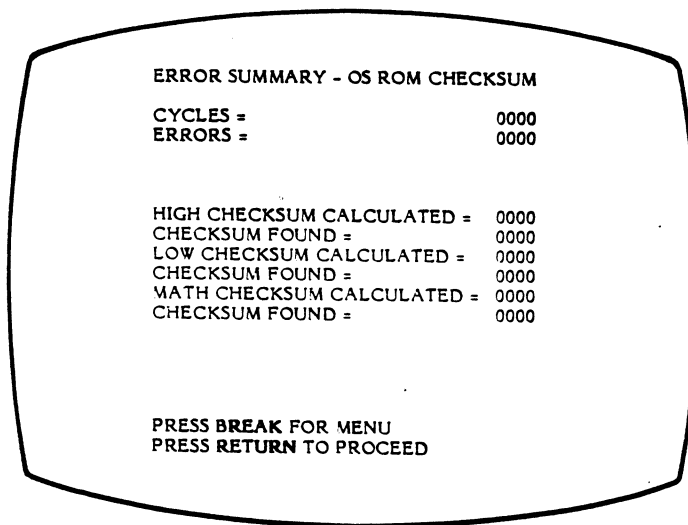

Figure 2-30. OS ROM Checksum Error Summary Screen

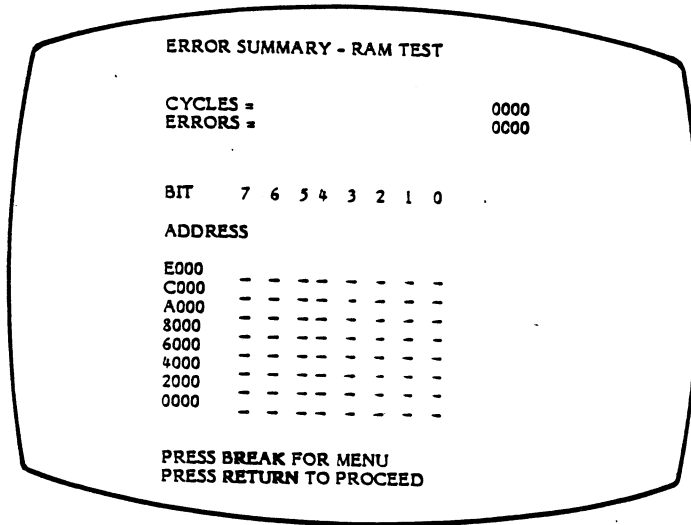

Figure 2-31. RAM Error Summary Screen

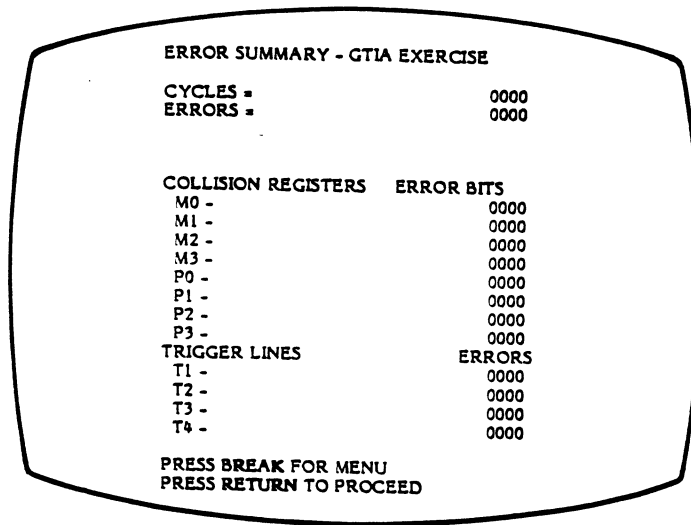

Figure 2-32. GTIA Error Summary Screen

```

ERROR SUMMARY - PIA EXERCISE

CYCLES =                0000
ERRORS =                0000

PIA PORT LINES
PORT A-B BIT 0          0000
PORT A-B BIT 1          0000
PORT A-B BIT 2          0000
PORT A-B BIT 3          0000
PORT A-B BIT 4          0000
PORT A-B BIT 5          0000
PORT A-B BIT 6          0000
PORT A-B BIT 7          0000
CONTROL LINES
CA1-CA2                0000
CB1-CB2                0000

PRESS BREAK FOR MENU
PRESS RETURN TO PROCEED

```

Figure 2-33. PIA Error Summary Screen

```

ERROR SUMMARY - POKEY EXERCISE

CYCLES =                0000
ERRORS =                0000

POT LINES
P0 -                    X          0000
P1 -                    X          0000
P2 -                    X          0000
P3 -                    X          0000
P4 -                    X          0000
P5 -                    X          0000
P6 -                    X          0000
P7 -                    X          0000
OTHER POKEY LINES
CLOCK LINES            0000
SIO LINES              0000

PRESS BREAK FOR MENU
PRESS RETURN TO PROCEED

```

Figure 2-34. POKEY Error Summary Screen

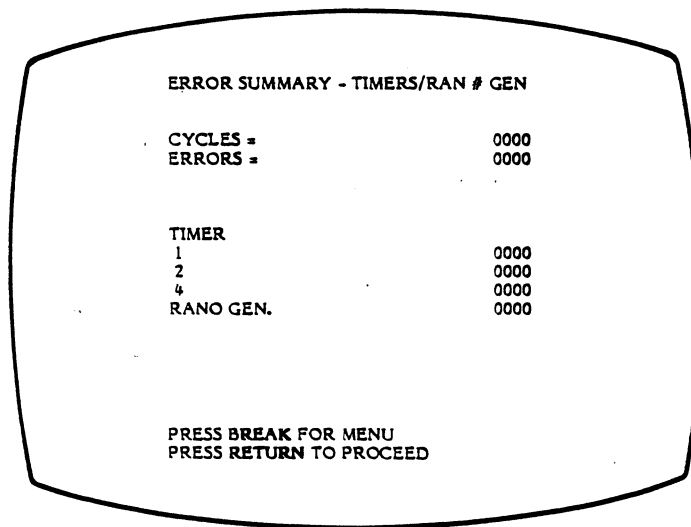

Figure 2-35. Timers/RAN # Gen Error Summary Screen

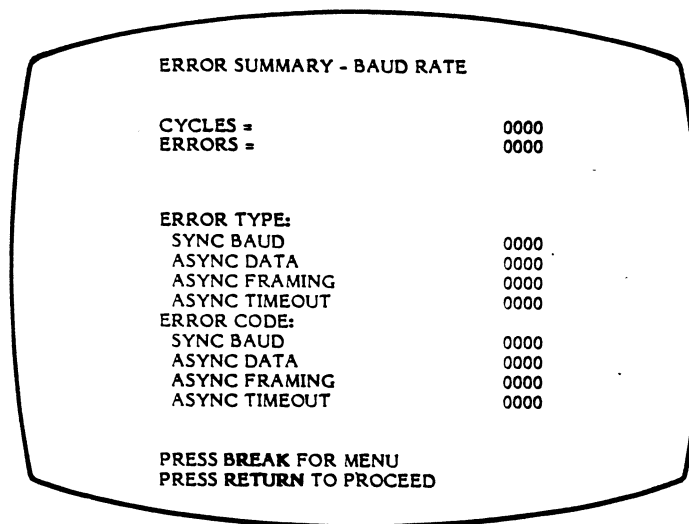

Figure 2-36. Baud Rate Error Summary Screen

POT LINE failures shown in Figures 2-33 and 2-34 decode as follows:

- A = Possible short to +5V
- B = Time constant to long
- D = Time constant to short
- E = A & D

These Error Summaries are useful in pin-pointing the exact cause of failure. Most tests have sub-tests whose failures are listed in the error summary.

Important: All error summary tables are zeroed when SYSTEM RESET is used and during power-up. Do not use SYSTEM RESET to return to EXECUTIVE MENU if accurate error reporting is desired.

FATAL SYSTEM ERROR DEFINITIONS

(What the system was trying to do when it happened)

<u>CODE</u>	<u>FUNCTIONAL TEST IN PROGRESS</u>
04	Refresh Check on Pattern "FF"
05	Address Line Check (could not get "unique" addresses using each line)
06	Address Line Check (could not get "unique" addresses using each line)
07	Data Line Check (one or more stuck hi or lo)
08	Refresh test in pattern "00"
09	RAM somewhere in page 0 or 1
10	RAM failure in page 0 (approx area \$004D \$007F)
11	RAM failure in page 0 (approx area \$004D \$007F)
17	RAM failure in page 0 (address \$0038) Data read = data stored
18	Ram failure in page 0 (address \$0019) Data read = data stored
97*	Not enough stack entries present (same as 98, in different terms)
98*	Stack overflow or underflow has occurred.
99*	RAM error in page 1 or system has taken a bad branch somewhere.

*97, 98, 99 related to address decoding on ROM or RAM or to bad CPU

This concludes 600XL Testing and Troubleshooting

For further assistance call:

Inside California
(800) 672-1466

Outside California
(800) 538-1535

SECTION 3

SYMPTOM CHECKLIST

The Symptom Checklist is designed to aid the technician in arriving at, listed in the order of failure, rapid diagnosis of problems. Each symptom is accompanied by some possible causes, and suggested remedies. **Instructions for disassembly/assembly, are in SECTION 4 of this manual.**

<u>SYMPTOM</u>	<u>POSSIBLE CAUSES</u>	<u>REMEDY</u>
Snowy Screen	Switch Box, DC Power Supply and ON/OFF switch, Channel Select Switch, RF modulator, or Damaged RF cable.	Adjust or replace.
Black/Gray Screen	+5 voltage from supply. Verify all voltages +5A,B,C. Verify Y1.	Troubleshoot Power Supply (Voltage +5A,B & C on PCB) Verify 3.58 MHz freq. of Y1.
Green/Yellow Screen	U1-7, U11-U16	Repair or Replace.
Solid Blue Screen	U1-2, U4	Troubleshoot BASIC ROM & Support Circuit Replace or repair.
No Color or Bad Color	U17,U19,Q6,Q1,CR1-2 Y1, RF modulator, or TV Tuner R43,U8	Adjust or replace, RF Modulator Adjust or Color Adjust.
No Power Light (L1)	Power LED, Power Supply, Cables	Repair or Replace.
No Gray Bars or Missing Bar	U17, U19	Repair or Replace.
Upside down Alpha/ Numerics on Player Field	U9	Replace.
Some Keyboard Keys Fail*	U20, Keyboard, U22, U23,Cable	Repair or Replace.
All Keyboard Keys Fail*	U20, 22, 23	Repair or Replace.
Tone or Tones Missing During Tone Test	U20, 4.5MHz, U8, Audio Carrier Frequency,TV volume	Repair, Adjust 4.5 MHz on RF Modulator. Replace if necessary.
Console Game Switches** Will Not Functon	U17, Switches, Cable	Repair or Replace
ROM Test Failed	U1-U4	Repair or Replace.

<u>SYMPTOM</u>	<u>POSSIBLE CAUSES</u>	<u>REMEDY</u>
RAM Test Failed	U1, U2, U5-7, U11-16, U18	Verify U18 is <u>74S32</u> .** Verify ANTIC is <u>Rev E</u> . Repair or Replace. (TT #20)
Video or ANTIC Stress Fail	U7, U9	Repair or Replace.
I/O Port Test Fail*** Joystick Paddle***	U20,U21,Q4,J1,J5,J6	Repair or Replace.
CPU Test Fail	Y1,Q2,Q3,U10	Verify 3.58 MHz osc. frequency. Repair or Replace.
2-Way Clock Fail***	J1, U20	Repair or Replace.
External Audio***	J1, U8	Repair or Replace.
GTIA Fail	U17	Replace.

* Keyboard and switches require operator intervention

** MUST have correct IC's or RAM will fail.

***Requires the super SALT Extended Hardware Test Module, jumper cables, power supply for correct operation. Joystick and Paddle Test require user action with a joystick and paddle during respective testing.

SECTION 4

DISASSEMBLY/ASSEMBLY INSTRUCTIONS

ATARI 600XL™ Console-Disassembly

The following describes the procedures to disassemble the 600XL Console.

Hardware Access

- o Turn unit upside down
- o Remove four screws from bottom cover
- o Turn unit upright
- o Tip cover by raising the left side allowing access cable. Carefully remove keyboard cable from socket and lay top aside.

PCB Removal

- o Using a magnetic screwdriver remove screw accessible thru RF shield on top left.
- o Remove 4 remaining screws
- o Remove PCB & RF Shield
- o Remove 6 bolts and nuts from RF shield

Assembly

Reassemble in reverse order

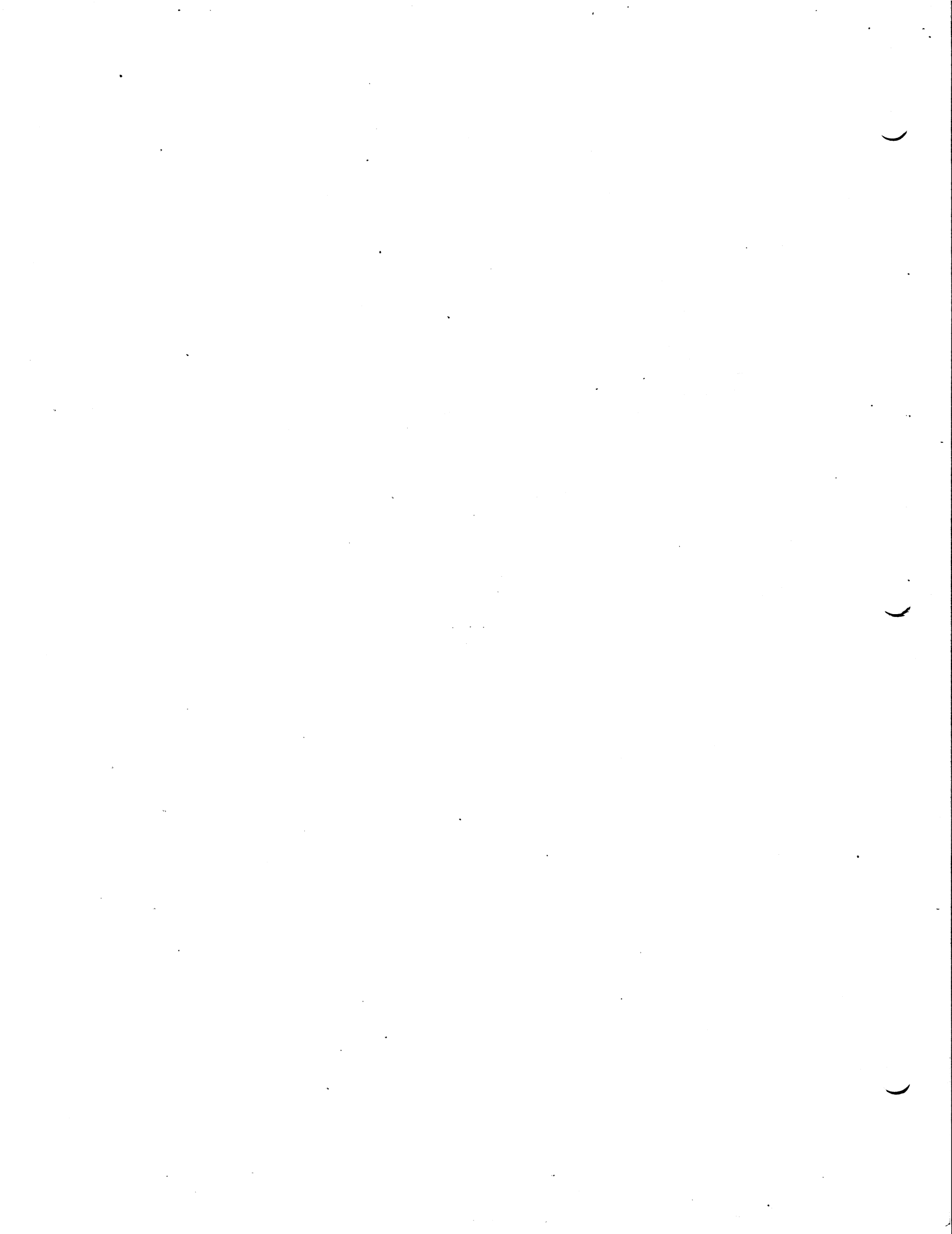

SECTION 5

SCHEMATICS AND SILKSCREENS AND PARTS LIST

The schematic and silkscreen for the 600XL are attached to the front cover of this manual.

Editor's Note:

Due to oversights during the editing of the 600XL schematic the following errors were not corrected on that schematic. Please make the following corrections with pen and ink.

1. In the lower left corner of the schematic, NOTES FOR DOMESTIC UNITS ONLY, change NOTE 2. to read:
 2. CHANGE Y1 CRYSTAL, C015510, 3.546894 MHz to C061090, 3.579545 MHz.
2. In the dotted box containing the words RF MODULATOR please add, NOTE 1.
3. In the dotted box containing the word CRYSTAL please add, NOTE 2.
4. In the largest dotted box, located at the bottom center of the schematic, containing U24, please add, NOTE 3.
5. In the reversed L shaped dotted box above the POKEY (U20), please add, NOTE 4.
6. Change Resistor to the left of RF Modulator labeled R12 valued at 2K in series with C100 to R112/12K.

Minor variations in design may be encountered depending upon the production date of the console. The attached drawings provide all details required for an in-depth understanding of the 600XL.

The parts list contains first a listing of 600XL unique components, then the complete part list.

NOTE: The schematic is a domestic/U.K. version. All U.K. additions are shown in dotted boxes. READ the notes at the bottom left corner before any troubleshooting is performed.

Place drawings attached to the front cover behind this page.

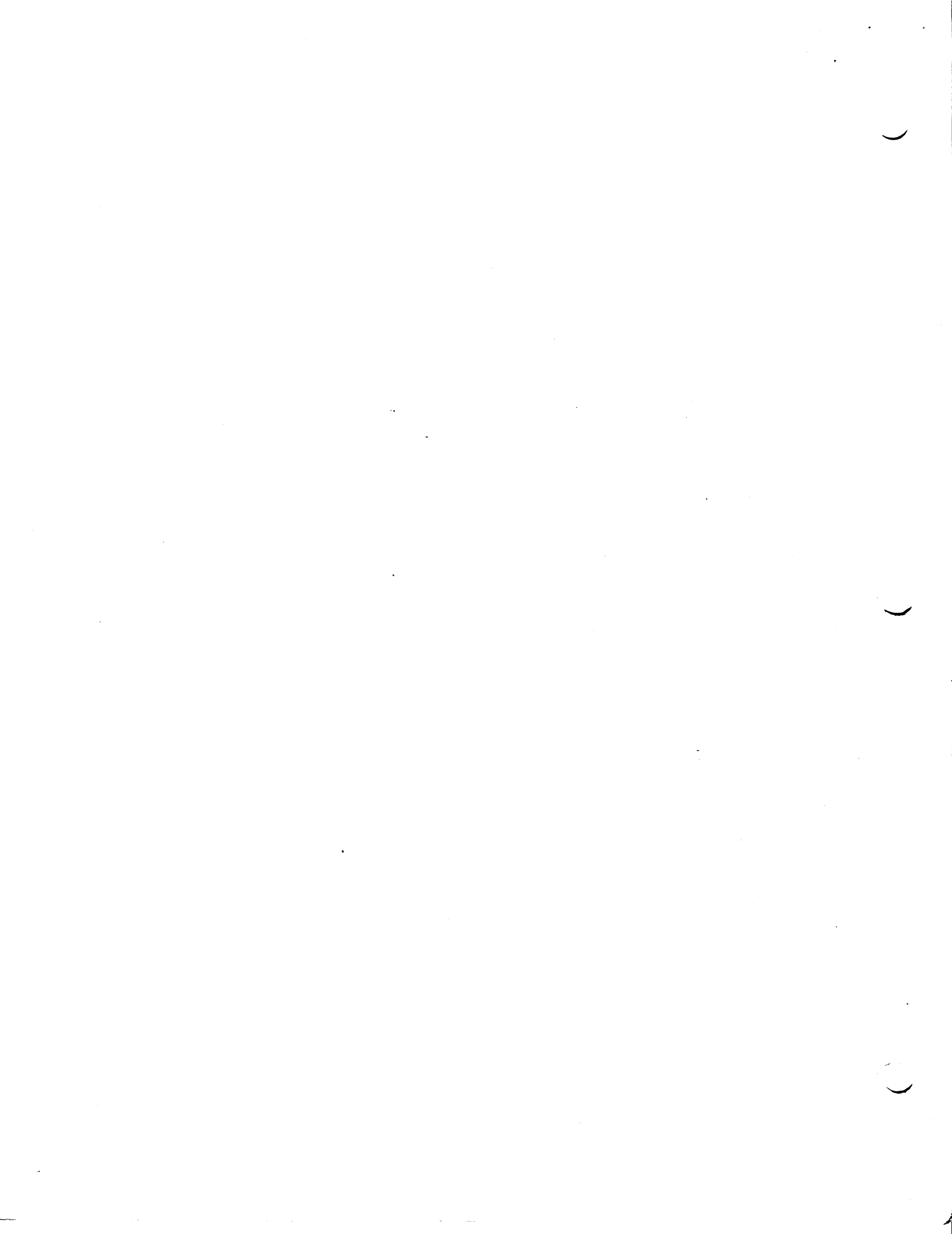

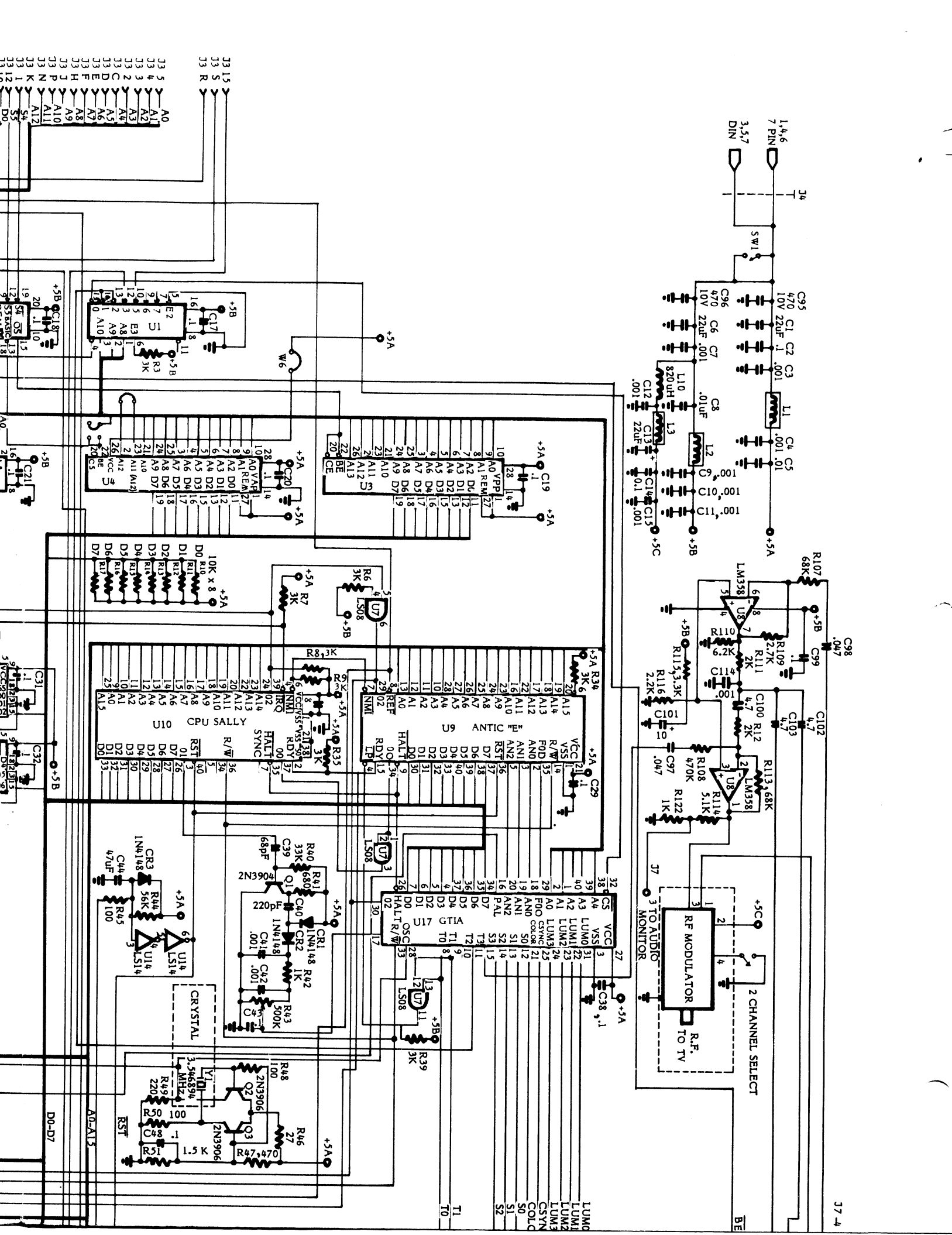

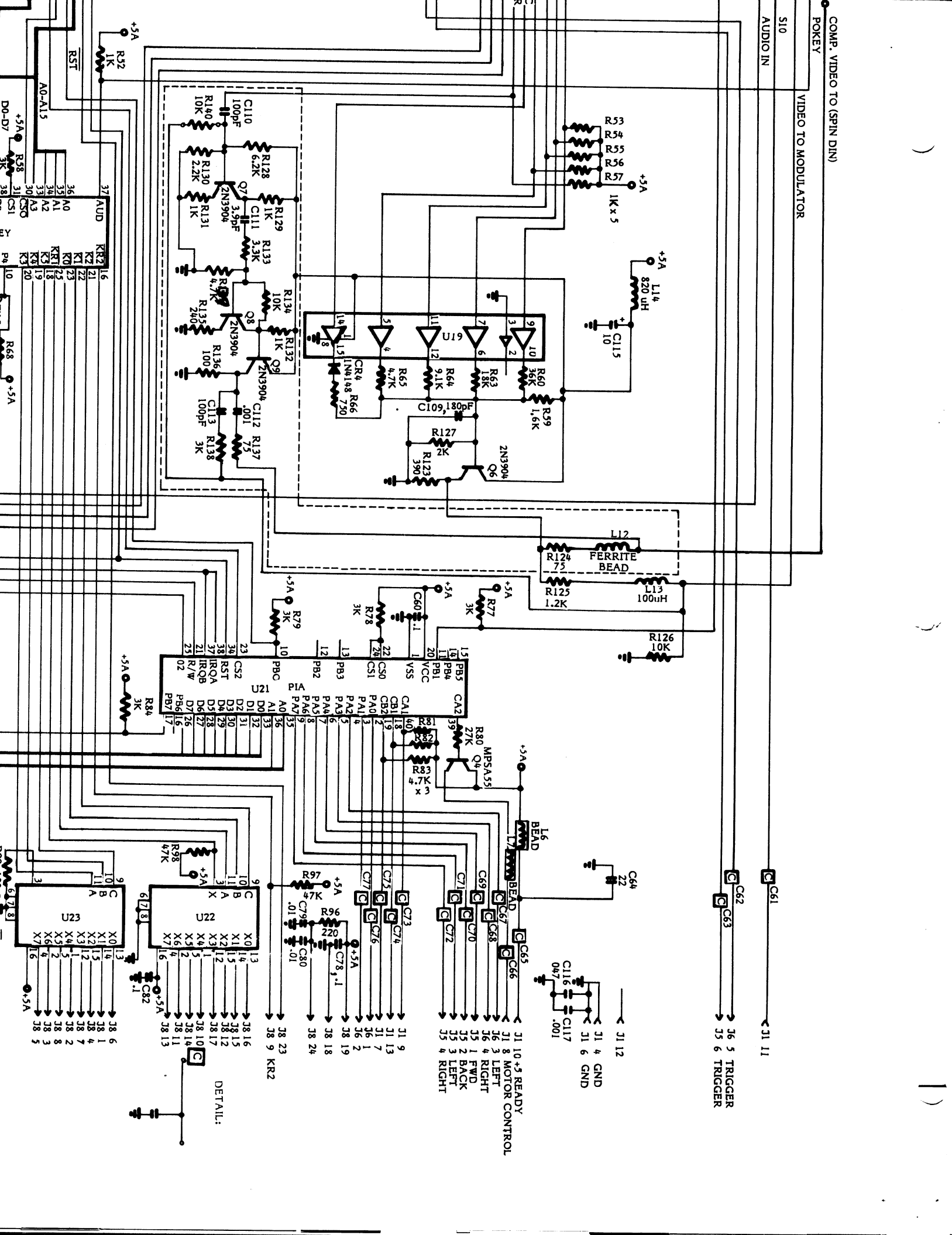

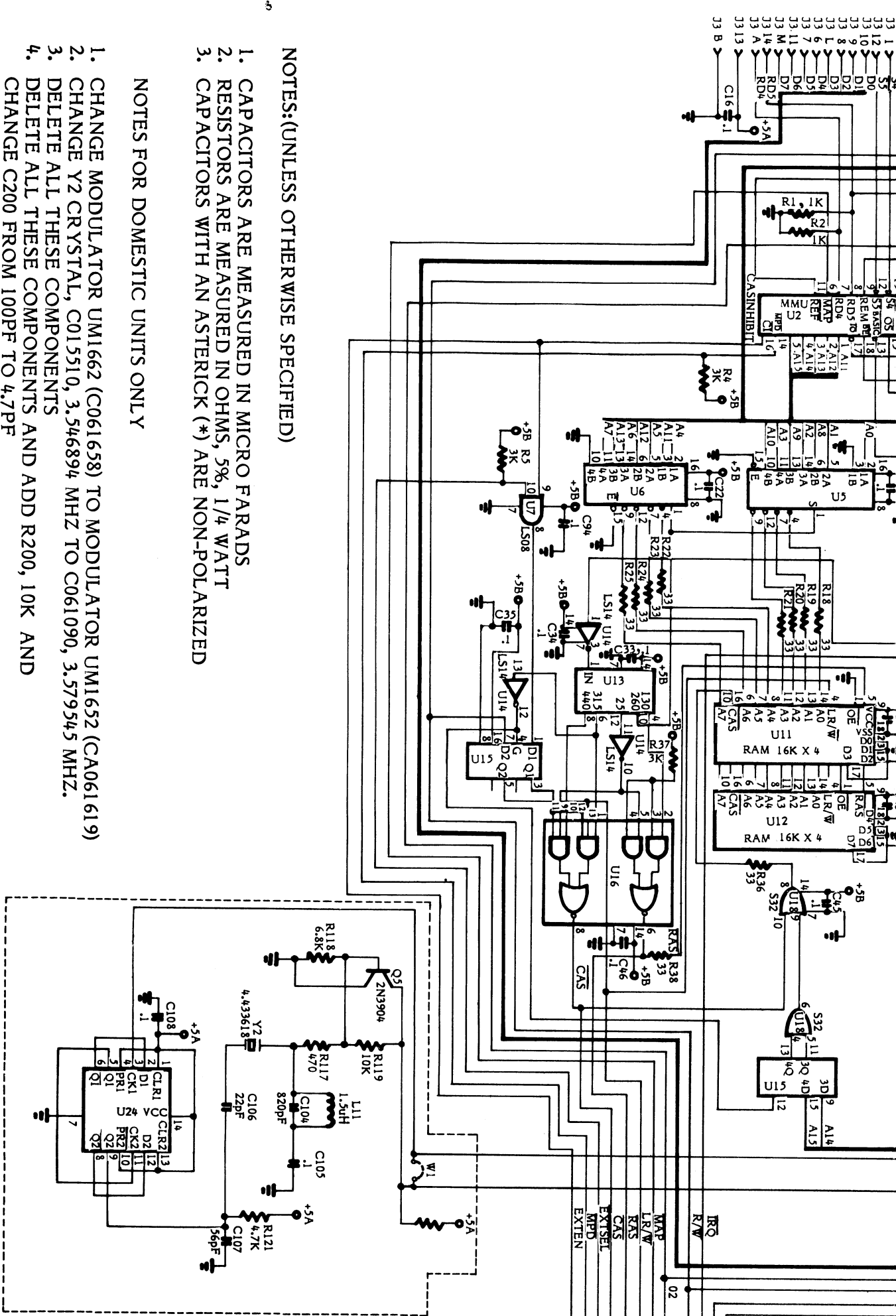

- NOTES: (UNLESS OTHERWISE SPECIFIED)
1. CAPACITORS ARE MEASURED IN MICRO FARADS
 2. RESISTORS ARE MEASURED IN OHMS, 5%, 1/4 WATT
 3. CAPACITORS WITH AN ASTERICK (*) ARE NON-POLARIZED
- NOTES FOR DOMESTIC UNITS ONLY
1. CHANGE MODULATOR UMI662 (C061658) TO MODULATOR UMI652 (CA061619)
 2. CHANGE Y2 CRYSTAL, C015510, 3.546894 MHZ TO C061090, 3.579545 MHZ.
 3. DELETE ALL THESE COMPONENTS
 4. DELETE ALL THESE COMPONENTS AND ADD R200, 10K AND CHANGE C200 FROM 100PF TO 4.7PF

600XL SCHEMATIC

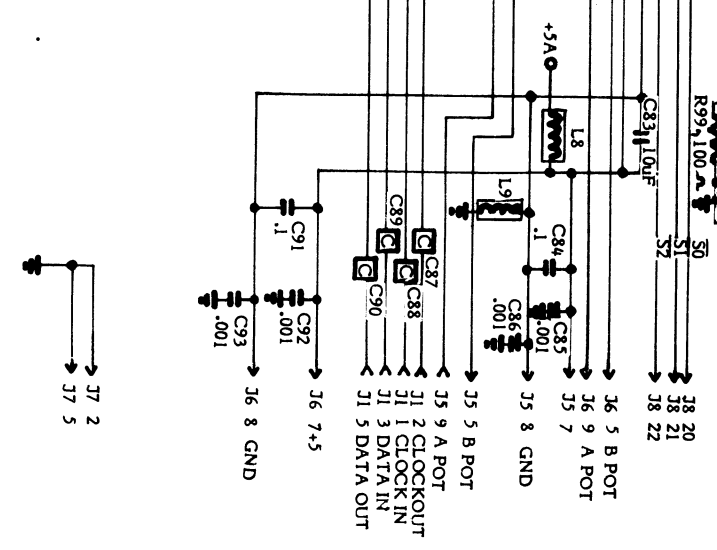
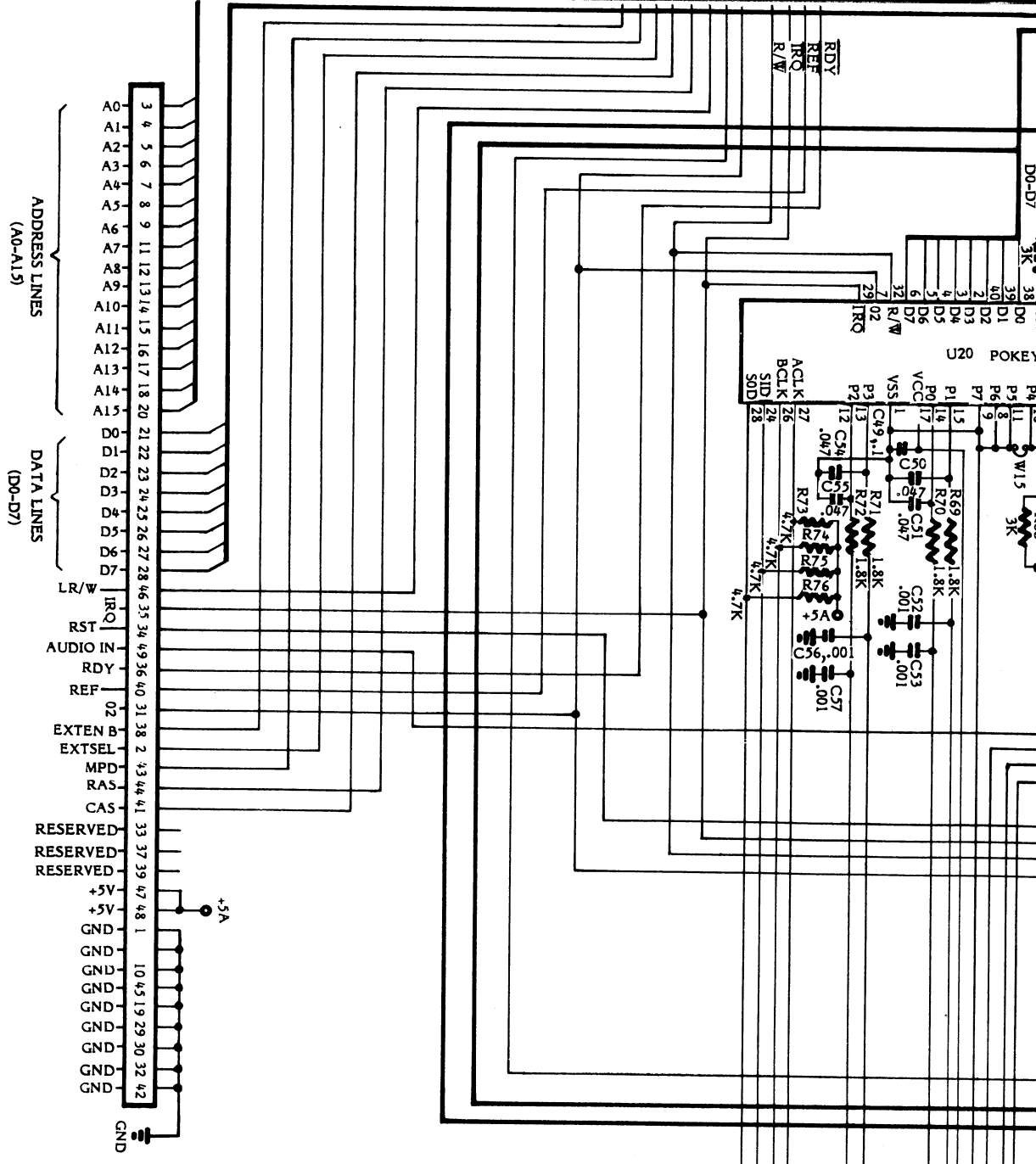

+

+

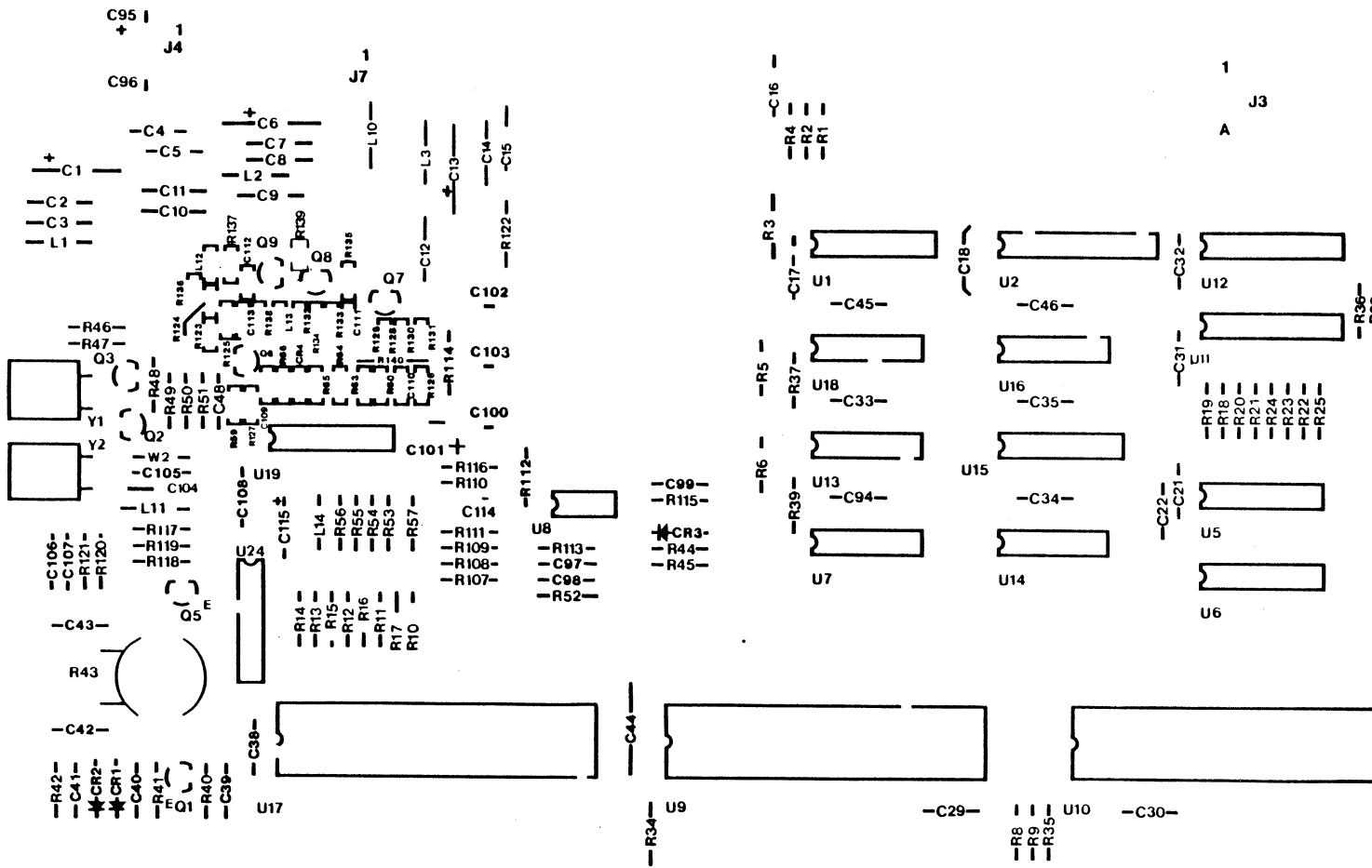

FIGURE 5-1 600XL SILKSCREEN

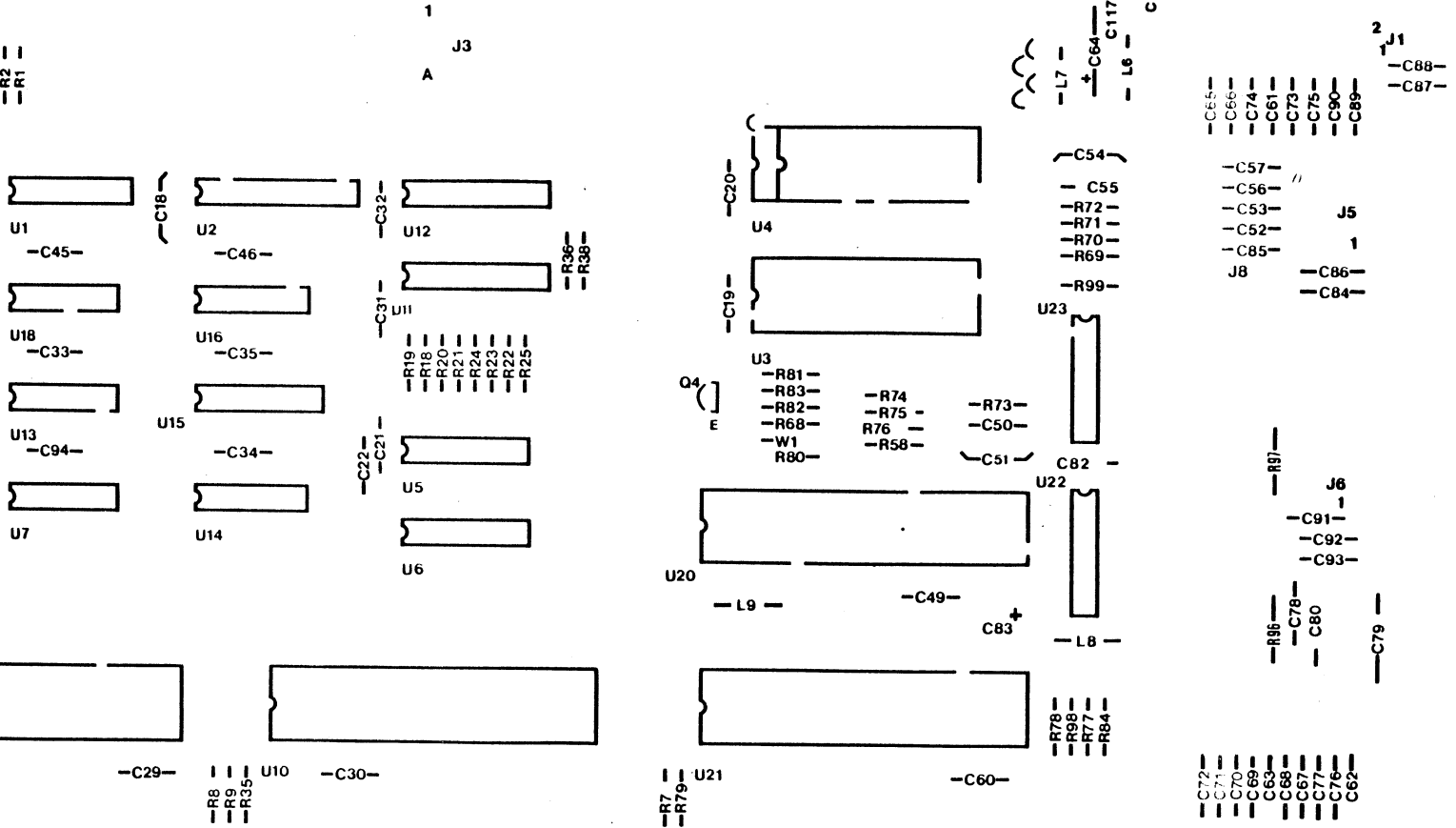

FIGURE 5-1 600XL SILKSCREEN

600XL PARTS LIST

<u>Description</u>	<u>Part Number</u>
Final Assembly	CA061615-00
RFI Shield, Top	C061999
RFI Shield, Bottom	C062000
Cartridge Guide	C060297
Power Supply	CA061982
TV Switch Box (Packaged)	CA014746
Console Assembly	CA061614
Keyboard	CA061983
RF Cable	C061177
RF Cable Adaptor	C061959

600XL UNIQUE PARTS

<u>Location</u>	<u>Description</u>	<u>Part Number</u>
	5 Volt DC Power Supply	CA061982
U2	MMUIB IC	C061618
U3	27128 16K X 8 OS ROM IC	C061598
U4	2764 BASIC ROM Rev. B IC	C060302
U9	ANTIC Rev. E IC	C021697
U10	6502C CPU IC	C014806
U11-12	16K X 4 DRAM IC	C061505
U18	74S32 IC	C061622
UM11652E	Domestic RF Modulator	C061619

600XL PARTS LIST

<u>Location</u>	<u>Description</u>	<u>Part Number</u>
C1,6,13,64	Cap 22uF +50 -20% 16V Elec. Axial	C014393
C2,3,14,16-22, 29-35,38,43,45, 46,48,49,60,78, 81,82,84,91,94, 99	Cap .1uF Cer. Axial +80 -20%	C014181-03
C4,7,9-12,15, 41,42,52,53,56, 57,61-63,65-77, 85-90,92,93,114, 117	Cap .001uF Cer. Axial +80 -20%	C014181-01
C5,8,79,80	Cap .01uF Cer. Axial +80 -20%	C014181-02
C39	Cap 68pF Cer. Axial 10% NPO	C014179-10
C40	Cap 220pF Cer. Axial 10%	C014180-05
C44	Cap 47uF +50 -20% 10V Elec. Axial Lead	24-100476

600XL PARTS LIST

<u>Location</u>	<u>Description</u>	<u>Part Number</u>
C50,51,54,55 97,98,116 C83,101,115	Cap .047uF Cer. Axial 10%	C014180-09
C95,96	Cap 10uF +50 -20% 16V Alum. Elec	C014371
C100,102,103	Cap 470uF +50 -20% 10V Elec. Axial Lead	C014370
C109	Cap 4.7uF +75 -10% 35V Non Polarized	C061647
C200	Cap 180pF Cer. Axial 10% NPO	C061336-05
R1,2,42,52-57 122	Cap 4.7pF Cer. Axial 10%	C014179-26
R3-9,35,37,39 58,68,77-79, 84,174	1K Ohms Resistor 1/4W 5%	14-5102
R10-17,126,200	3K Ohms Resistor 1/4W 5%	14-5302
R18-25,36,38	10K Ohms Resistor 1/4W 5%	14-5103
R40	33 Ohms Resistor 1/4W 5%	14-5330
R41	33K Ohms Resistor 1/4W 5%	14-5333
R43	680 Ohms Resistor 1/4W 5%	14-5681
R44	500K Ohms Trimpot	19-411504
R45,48,50,99	56K Ohms Resistor 1/4W 5%	14-5563
R46	100 Ohms Resistor 1/4W 5%	14-5101
R47	27 Ohms Resistor 1/4W 5%	14-5270
R49,96	470 Ohms Resistor 1/4W 5%	14-5471
R51	220 Ohms Resistor 1/4W 5%	14-5221
R59	1.5K Ohms Resistor 1/4W 5%	14-5152
R60	1.6K Ohms Resistor 1/4W 5%	14-5162
R63	36K Ohms Resistor 1/4W 5%	14-5363
R64	18K Ohms Resistor 1/4W 5%	14-5183
R65,73-76,81-83	9.1K Ohms Resistor 1/4 W 5%	14-5912
R66	4.7K Ohms Resistor 1/4W 5%	14-5472
R69-72	750 Ohms Resistor 1/4W 5%	14-5751
R80	1.8K Ohms Resistor 1/4W 5%	14-5182
R97,98	27K Ohms Resistor 1/4W 5%	14-5273
R107,113	47K Ohms Resistor 1/4W 5%	14-5473
R108	68K Ohms Resistor 1/4W 5%	14-5683
R109	470K Ohms Resistor 1/4W 5%	14-5474
R110	2.7K Ohms Resistor 1/4W 5%	14-5272
R111,112,127	6.2K Ohms Resistor 1/4W 5%	14-5622
R114	2K Ohms Resistor 1/4W 5%	14-5202
R115	5.1K Ohms Resistor 1/4W 5%	14-5512
R116	3.3K Ohms Resistor 1/4W 5%	14-5332
R123	2.2K Ohms Resistor 1/4W 5%	14-5222
R125	390 Ohms Resistor 1/4W 5%	14-5391
W2,3,15	1.2K Ohms Resistor 1/4W 5%	14-5122
L1,2,3,6,7,8,9	0 Ohm Resistor 1/4W 5%	C060629
L10,14	Inductor Ferrite Bead	C014384
L13	Inductor 820uH Axial 10%	C017948-03
	Inductor 100uH Axial 10%	C017948-04

600XL PARTS LIST

<u>Location</u>	<u>Description</u>	<u>Part Number</u>
CR1,2,3,4	Diode 1N4148	C060607
Q1,6	Transistor 2N3904 NPN	34-2N3904
Q2,3	Transistor 2N3906 NPN	34-2N3906
Q4	Transistor MPSA55	C014809
Y1	Crystal 3.579545MHz	C061090
SW1	Switch, Power Vertical SPDT	C061913
SW2	Switch, Channel	C012241
UM11652E	Modulator DOM, UM1652E	C061619
J1	Conn. 13 Pins, Right Angle	C012995
J3	Conn. 30 Pins, Cartridge	C014389
J4	Conn. 7 Pins Din Power	C061838
J5, 6	Conn. 9 Pins, Right Angle	C010448
J8	Conn. 24 Pins, Keyboard Header	C061793
U1	IC 74LS138 Decoder	C061428
U2	IC MMU1B Memory Mngt I.C.	C061618
U3	IC 16K X 8 OS ROM	C061598
U4	IC 8K X 8 BASIC ROM Rev B	C060302
U5,6	IC 74LS158 Multiplexer	C014345
U7	IC 74LS08 Quad AND	C017097
U8	IC LM358 Dual Op AMP	C061702
U9	IC ANTIC E	C021697
U10	IC 6502C CPU	C014806
U11,12	IC 16K X 4 RAM	C061505
U13	IC Delay Module	C060472
U14	IC 74LS14 Hex Inverter	C061850
U15	IC 74LS375 Latch	C060613
U16	IC 74LS51 AND/OR Inverter	C060474
U17	IC GTIA	C014805
U18	IC 74S32 Quad OR	C061622
U19	IC C04050B Hex Buffer CMOS	C010816
U20	IC POKEY	C012294
U21	IC PIA	C014795
U22,23	IC C04051B MUX	C014336
U1,5,6,15,19 22,23	Socket, 16 Pins	C014386-03
U2	Socket, 20 Pins	C014386-05
U3,4	Socket, 28 Pins	C014386-08
U7,13,14,16,18	Socket, 14 Pins	C014386-02
U8	Socket, 8 Pins	C014386-01
U9,10,17,20,21	Socket, 40 Pins	C014386-09
U11,12	Socket, 18 Pins	C014386-04

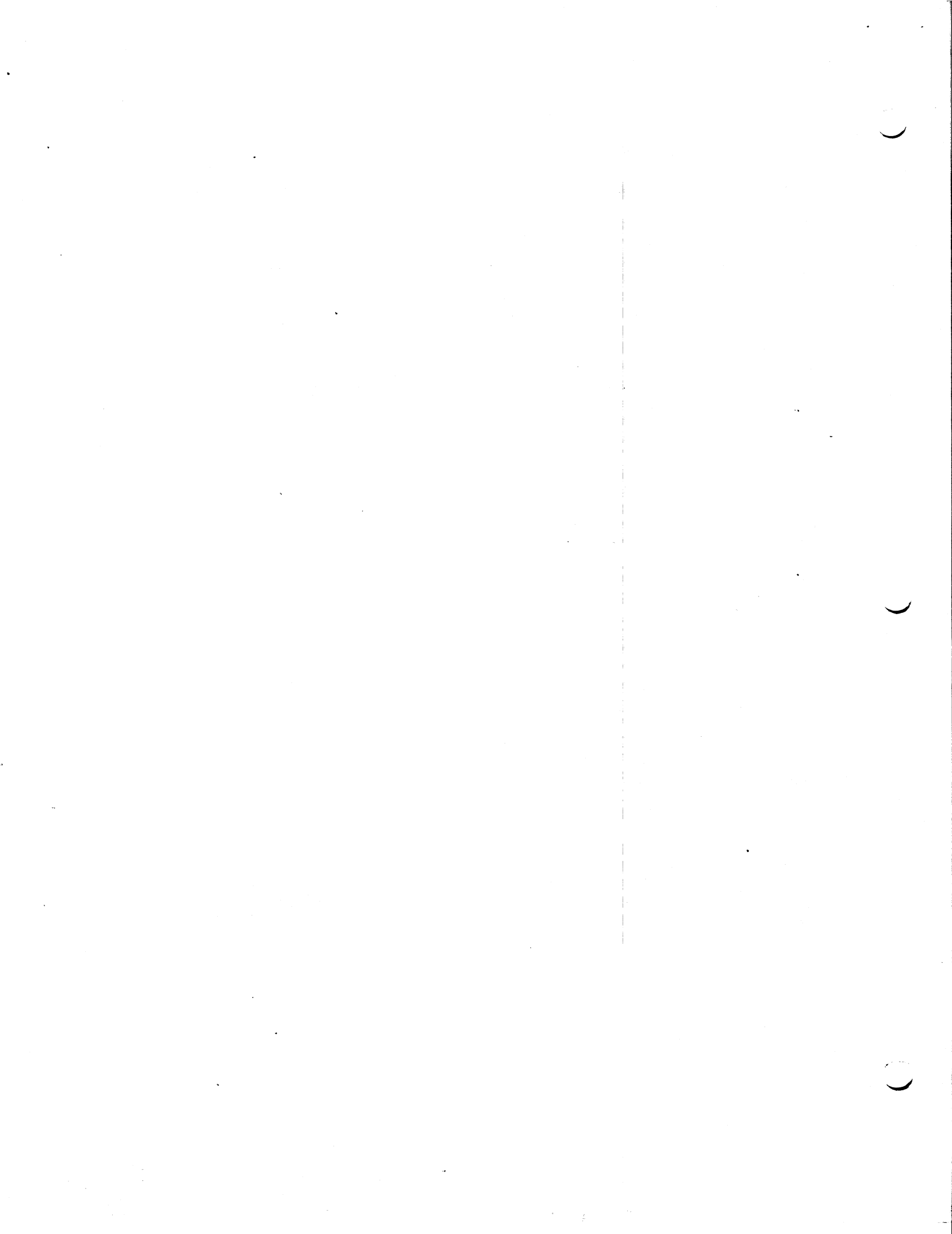

SECTION 6

SERVICE BULLETINS

This section is to be used by you to file the three classifications of service bulletins that are periodically released by the Director of Technical Support.

The following are brief descriptions of each classification:

FIELD CHANGE ORDER

A Field Change Order describes mandatory hardware or software changes to ATARI products and instructs how to implement these changes. The changes must be performed on all units serviced or repaired.

UPGRADE BULLETIN

An Upgrade Bulletin describes product improvements or modifications that the consumer may wish to purchase. These bulletins allow you to modify the customer's unit to add capabilities which may not have been available when the unit was originally manufactured.

TECH TIP

A Tech Tip is a document of a general nature which transmits routine service or repair information. By communicating methods developed since you attended training classes, Tech Tips aid to continuously improve repair skills and increase knowledge of ATARI products.

Other times, Tech Tips alert you to units that have been modified and are now standard for ATARI Manufacturing, but are different from many existing units and require different repair techniques.

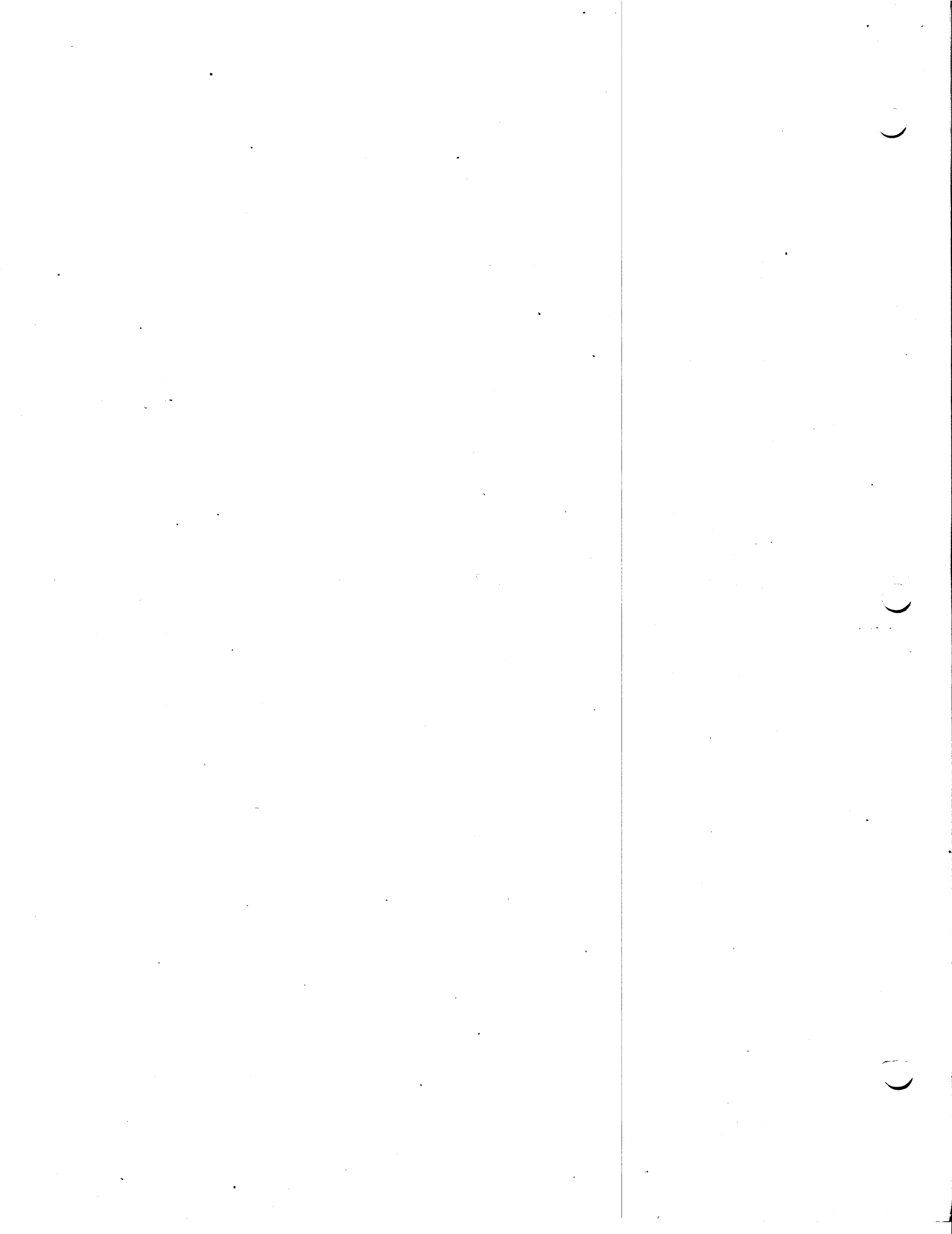



Consumer Product Service
Manager of Technical Support
TECH TIP

TT
HCD
20

number

MODEL: Atari 600XL CPU

DATE: August 17, 1983

SUBJECT:

Problems running the SALT or SUPERSALT RAM test and loading software.

DESCRIPTION:

The first 24K International and possibly some of the Domestic 600XL units will fail RAM diagnostics when using Super SALT. Likewise, most application programs which turn off the screen for any reason, will fail.

PROBLEM:

In most cases the reason for the failure will be due to the wrong version of the ANTIC chip having been installed during manufacturing.

SOLUTION:

It is important that you first verify that the ANTIC is the proper revision (C021698) for International 600XL's, and C021697 for Domestic units. Should you find that the proper ANTIC has not been installed, install the correct I.C. using the information cited below.

INTERNATIONAL - Location U9 - Part Number C021698

DOMESTIC - Location U9 - Part Number C021697

TESTING AND TROUBLESHOOTING

Use the standard testing procedures outlined in the 600XL Field Service Manual (FD100610).

DIFFICULTY REPORTING:

If you have questions or require further explanation concerning this Tech Tip, contact your ATARI Techline Specialist:

Inside California
(800) 672-1466

Outside California
(800) 538-1535

TELEX: 172870
Attn: Techline Specialist (845)

